



JAGWIRETM

Trademarks

All trademarks, service marks and trade names of Jagwire and Chia Cherne used herein are trademarks or registered trademarks of the Chia Cherne Industry Company, Ltd. Use of any trademarks or other intellectual property of Chia Cherne, without the express written consent of Chia Cherne, is prohibited.

商標

所有Jagwire和佳承精工所使用之商標、行業標及商品名稱都已註冊為佳承精工股份有限公司所有。禁止未經我司許可隨意使用佳承精工之商標及智慧財產權。

Copyright

(c) 2008-2009 Chia Cherne Industry Company, Ltd. Chia Cherne Industry Company, Ltd Warranty Policy

Extent of Limited Warranty

Chia Cherne/Jagwire warrants its products to be free from defects in materials or workmanship for a period of two years after original purchase. This warranty only applies to the original owner and is not transferable. Claims under this warranty must be made through the retailer where the bicycle or the Jagwire product was purchased. Original proof of purchase is required.

產品保固期限

自購買日起，佳承精工/Jagwire對於材質及成品的保固期間為兩年，此權利僅適用於原購買者享有且不得轉讓。在期限內若需更換產品，須提供原始購買憑證，此權利賦予Jagwire授權之正式經銷商。

Local law

This warranty statement gives the customer specific legal rights. The customer may also have other rights which vary from place to place. To the extent that this warranty statement is inconsistent with the local law, this warranty shall be deemed modified to be consistent with such law, under such local law, certain disclaimers and limitations of this warranty statement may apply to the customer.

當地法令

本保固聲明賦予顧客專有的權利，顧客也可能擁有其他因地而異的權利，當本保固服務的範圍如與當地法令不一致，則保固聲明將自動修正與該當地法令一致或依據當地法令或放棄權利，此保固聲明的限制也適用當地顧客。

Limitations of Warranty

This warranty does not apply to products that have not been correctly installed and/or adjusted or maintained according to the respective Chia Cherne/Jagwire technical installation manual.

This warranty does not apply to damage to the product caused by a crash, impact, abuse of the product, noncompliance with manufacturers specifications of usage or any other circumstances in which the product has been subjected to forces or loads beyond its design.

This warranty does not apply when the product has been modified.

This warranty does not apply to normal wear and tear. Chia Cherne/Jagwire does not consider use in racing and competition to be normal wear and tear. Wear and tear parts are subject to damage as a result of normal use, failure to install and service parts according to recommendations and/or riding or installation in conditions or applications other than recommended. Wear and tear parts are identified as:

o Brake pads	o Cables
o Housings	o Housing end caps
o Adjusters	o Guide pipes

This warranty shall not cover damages caused by the use of parts of different manufacturers.

This warranty shall not cover damages caused by the use of parts that are not compatible, suitable and/or authorized by Chia Cherne/Jagwire for use with components other than those for they are designed to be compatible with.

Effective Date: January 1, 2007

保固限制

1. 在顧客未依照佳承精工/Jagwire原廠說明書在安裝、調整或維護過程中導致產品損壞的情況下不適用於本保固服務。
2. 當產品經撞擊、不當使用、未依循製造商提供的使用規範或產品已被變更為非原廠設計的情況下而導致損壞時則不適用於本保固服務。
3. 產品遭修改時不適用於本保固服務
4. 本保固服務不適用於正常性損耗。經競賽用途而導致的損耗，佳承精工/Jagwire亦不視為正常損耗。非依照建議指示而在使用、安裝及騎乘的情況下，易損耗零件容易因正常使用、組裝錯誤、維修而導致損壞。

被視為易損耗的零件有：

o 煞車皮	o 內線
o 外殼	o 端套
o 調整螺絲	o 彎管

5. 本保固服務範圍不涵蓋因使用其他廠牌零件所造成產品的損壞

6. 本保固服務範圍亦不適用於當顧客使用不相容的或非佳承精工/Jagwire授權認可的零件而導致的產品損壞。

生效日：2007.1.1

About Chia Cherne

Exploring New Horizons for Control Systems For more than 20 years, Chia Cherne, owners of the Jagwire brand names, has pioneered new territory in the manufacture of high performance control systems. As an ISO 9001/TS-16949 company we have an unyielding commitment to quality, constantly testing, stressing and abusing our brake pads, housings and cables under extreme conditions. We value feedback and actively listen to comments and suggestions from our OEM customers to our sponsored professional athletes to the local bike shop mechanic all the way to the occasional weekend rider.

關於佳承

二十餘年來，佳承-Jagwire品牌的擁有者，努力打造高性能操控系統全新領域使成為製造的先驅，並先後申請通過ISO 9001/TS-16949的品質管理認證，我們持續不懈以最嚴謹的方法來檢驗煞車、變速操控線組、煞車膠塊及相關零配件性能對產品品質的可靠性提供絕對的保證。我們重視並主動傾聽來自於OEM顧客、我們贊助的運動員、當地車店的專業技師及週末騎車出遊的愛好者其意見與建議。

Jagwire Goes Pro

Traditionally, many of our after-market control system products were released under respected private label brands. During the past three years we have invested heavily in developing a new class of control system products. Now, our latest and best technologies bear the Jagwire logo. We call these products "Pro," short for proprietary.

專業級Jagwire

Jagwire操控系統產品在傳統上受到自有品牌客戶的重視，過去三年，我們大量投入資源研發進階專業化的操控系統產品並以“Pro”系列命名配上Jagwire品牌專屬化。

Faster, Leaner, Better

Fully committed to continuous improvement, our experienced engineering and product management staff are always looking for ways to enhance the customers experience, provide maximum quality and value, reduce defects and increase overall customer satisfaction. Partnering with Toyota, we integrated the highly effective and efficient Toyota Production System. Our balanced blend of automation and manual processes helps us manage flow and volume, resulting in unsurpassed quality and efficiency. As a member of the Taiwan A-Team manufacturing group, we develop business strategies and tactics to reduce lead times, improve product quality, improve worker safety, satisfaction.

迅速、精實、卓越

堅持製程持續改善，Jagwire研發團隊不斷尋求各種方法幫助顧客節省開銷、增強產品品質、提升價值創新、減少失誤及增加顧客滿意度。以豐田汽車為標竿，效法高效能之豐田式生產管理系統，綜合自動化與手動製程，加速物流必要的數量在必要的時間供應到各工作站，進而成就優良品質和生產效益。身為台灣自行車協會(A-Team)的一員，我們的使命將透過妥善策略規劃、縮減交期、提升品質良率、消除不良與浪費，台灣立足全球高級自行車的製造中心。

Environment and Community

Recognizing our vital role as responsible global citizens, we strive to produce products that meet the exacting requirements of government agencies for performance, safety and environmental impact. Our primary control system products are CEN certified for the European Union and also passed California's Proposition 65 act for hazardous chemical content. Our active recycling program greatly reduces production related waste from our factories and we print our after-market product packaging using natural Soy based inks.

環境與群社：

體認身為地球的一份子，我們有責維護生態環境使之生生不息，並致力環保材料應用，使產品在性能要求、安全和環境各項嚴格的規範，取得平衡點。全系列產品均符合CEN標準規範並通過加州65法案且不含有毒之危害物質。我們積極推動的資源再利用計畫也大大降低了生產時造成的不必要浪費並將環保黃豆油墨應用在After-market產品包材上。



Things look different at Jagwire for 2013. Our image is cleaner, livelier and friendlier. We have exciting new products using new-to-the-category technology. Our product names are now simple and direct. This catalog is full of thoughtful details designed to make your bike look, feel and perform better. Most visibly all of this origination, performance, detail, and style is communicated in our new logo.

品牌形象的變更

Jagwire在2013年變得不同了；變得簡潔而純淨、清新而充滿活力、並以更友善的角度面對全世界；而這樣的改變也讓我們樂在其中！

我們採用了新技術提供更佳的产品，而我們的LOGO形象也更簡約而率直；這本全新的目錄充滿了我們對於產品的專注、以及對未來的想法。

全新的產品形象，包含了我們對產品的原創性、對於性能的要求、對於細節的專注、以及堅持完美的風格。

全新的Jagwire將提供給您更好的視覺感受、更佳的騎乘感受、以及更好的產品性能！

僅呈獻給熱愛自行車的您



INDEX 目錄

2	Company Info	公司簡介
6	Elite Low Friction System	極致操控系統
8	LINK SYSTEM	節式外殼系統
10	Inner Cable	內線系列
14	Bicycle Cable Housing	外殼系列
	CONTROL SYSTEMS	控制系統
	ACCESSORIES	配件
20	Installation Guide	零件裝配圖
22	Housing Parts	外殼零件
30	Tube Tops	保護套
31	Frame Parts	車架零件
35	Cable Parts	內線零件
41	Shifting Parts	變速零件
	BICYCLE HYDRAULIC DISC BRAKE PARTS	自行車油壓碟煞油管系列
48	Bicycle Hydraulic Disc Brake Parts	自行車油管碟剎相關零件
	DISC BRAKE PADS	來令片系列
54	Disc Brake Pads	來令片
	RIM BRAKE PADS	煞車皮系列
60	Brake Pads	煞車皮



new STS-LF 極致低摩擦內線

Slick Stainless Cable + Low Friction, Polymer Coating.

擁有獨特披覆層的低摩擦內線

To deliver the lowest possible friction, we developed a unique polymer coating that's applied during the cable extrusion process. By applying the coating this way all of the imperfections in the cable that can result in added friction are filled in resulting in the smoothest performance possible. And because the system depends on this coating, durability is critical which is why we focused on getting it just right for long lasting performance.

為了讓操控系統發揮最極致的效能，我們發展了獨特的內線披覆技術來降低摩擦係數。也因這獨特的披覆層，提供操控系統更準確、更耐久穩定的絕佳性能。

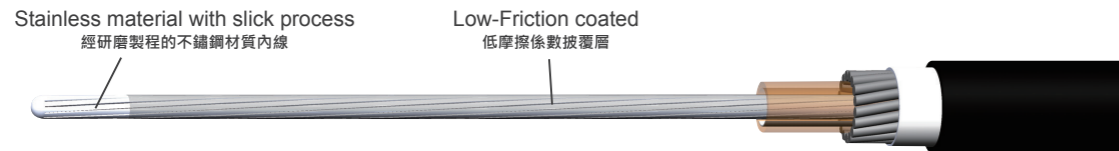

Reduced Friction 更低的摩擦係數

- ▲ Cable friction during shifting and braking is reduced by up to 14% vs competitive cables 與其他同類型產品比較，降低約14%的摩擦係數
- ▲ Reduced cable friction is critical to performance on frames with complex routing 有效改善車架走線時的摩擦問題

Increased Shifting Performance 提升變速的性能

- ▲ Shifting speed and precision is increased by up to 15%~25% 提升約15%~25%的換檔速度
- ▲ Developed to meet the demands of new 11-speed systems 與11段變速系統的完美演繹

Standard Low Friction System 低摩擦線組-標準系統

Shift and Brake housing + Speed-Lube.

擁有速動注油內管的全新外殼

Our shift and brake housing with Speed-Lube technology is designed to work with the STS-LF cables to deliver the best possible performance

運用速動注油內管技術外殼，搭配全新極致低摩擦內線(STS-LF)，提供操控最佳性能



Speed-Lube 速動注油內管

- ▲ Developed to work with the STS-LF coated cables 搭配全新極致低摩擦內線(STS-LF)
- ▲ Ultra slick formula is applied throughout the entire length of the housing during 整段外殼中皆包含全新配方的超低阻力潤滑油

Shift Housing 變速外殼

- ▲ 4mm outside diameter 適用外徑4mm
- ▲ Compressionless, linear strand shifting performance manufacturing 零壓縮比的直絲結構設計

Brake Housing 煞車外殼

- ▲ 5mm outside diameter 適用外徑5mm
- ▲ Durable, coiled steel construction 強韌的環狀結構設計



specified
此為標準規格



specified
此為標準規格

Sealed Low Friction System 低摩擦線組-全防護操控系統

Sealed Shift and Brake housing + Speed-Lube.

擁有速動注油內管的全防護系統

Sealed housing uses a continuous liner with seals to completely protect your system against dirt, mud and debris. With Speed-Lube technology is designed to work with the STS-LF cables to deliver the best possible performance

全防護系統採用從頭連貫至尾的內管設計，完全阻隔汙泥與雜質的影響
運用速動注油內管技術，搭配全新極致低摩擦內線(STS-LF)，提供操控最佳的性能



Speed-Lube 速動注油內管

- ▲ Developed to work with the STS-LF coated cables 搭配全新超極致低摩擦內線(STS-LF)
- ▲ Ultra slick formula is applied throughout the entire length of the liner during 整段內管中皆包含全新配方的超低阻力潤滑油

Shift Housing 變速外殼

- ▲ 5mm outside diameter 適用外徑5mm
- ▲ Compressionless, linear strand shifting performance 零壓縮比的直絲結構設計

Brake Housing 煞車外殼

- ▲ 5mm outside diameter 適用外徑5mm
- ▲ Durable, coiled steel construction 強韌的環狀結構設計



specified
此為標準規格



specified
此為標準規格

Color options 可供選擇顏色

- | | | |
|--|---|--|
|  #07 黑色
Black |  #01 白
White |  #56 紅色
Red |
|  #07Z 平光黑
Frozen Black |  #35Z 平光灰
Frozen Gray |  #20Z 平光咖啡
Frozen Coffee |

LINK SYSTEM 節式外殼系統

new Link Shift and Brake Systems 節式外殼系統



Slick-Lube Liner 順滑注油內管 Aluminum Links 鋁合金結式線管 End Cap 端套

Compressionless, Aluminum link construction.

全新的超低壓縮比節式結構

Aluminum link construction delivers some major benefits. It's compressionless delivering precision shifting, but it also allows for tight bends without kinking during tricky cable runs. It's also 20% lighter than traditional shift housing and 50% lighter than tradition brake housing. Combine these benefits with our slick-lube liners that dramatically reduce friction and you've got the best of performance and style.

全新的鋁製節式外殼結構設計，提供了大幅度的重量減輕、超低壓縮比，以及對應大角度彎曲的使用需求。搭配全順滑注油內管(Slick Lube)技術，提供絕佳的性能及與眾不同的風格。

Reduced Weight 超輕量化

- ▲ 50% lighter than traditional brake housing
較傳統煞車外殼結構輕量約50%
- ▲ 20% lighter than traditional shift housing
較傳統變速外殼結構輕量約20%

Compressionless Performance 超低壓縮比

- ▲ Compressionless aluminum construction delivers precision shifting and smooth, powerful braking
超低壓縮比的設計結構，不僅提供了精準的變速效能，亦能強化敏銳的煞車手感

Durable, Flexible Construction 靈活彎曲且耐用的結構

- ▲ Perfect for tricky cable runs with tight bends
靈活對應大角度彎曲的使用需求

Unique, Attention Grabbing Appearance 吸引目光的獨特設計

- ▲ Anodized finish is extremely durable and attractive
兼具品味及質感的外型設計

Color options

可供選擇顏色



P4 黑
Black



#P2 銀
Sliver



#P1 金
Gold

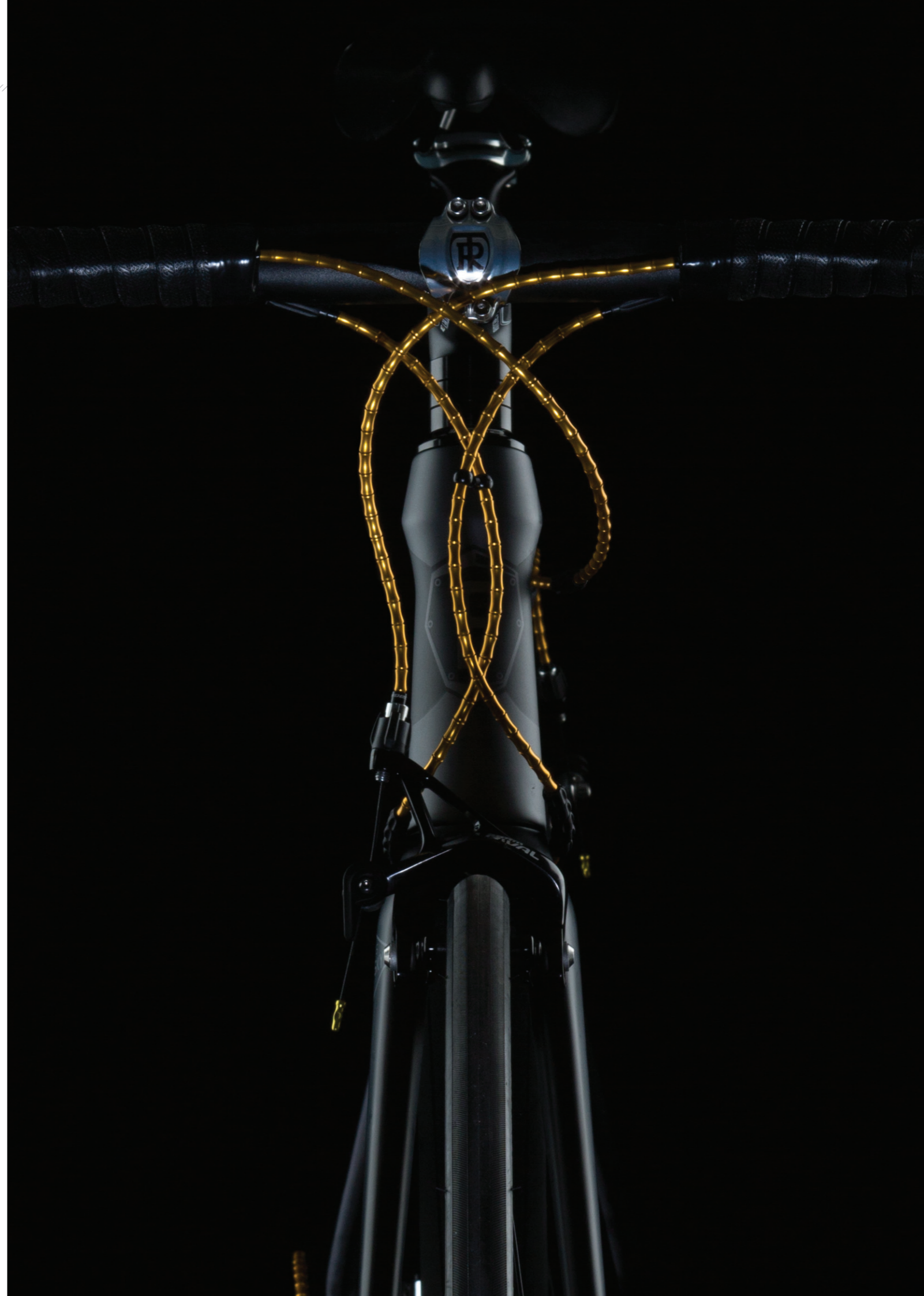

The tables below illustrate the structure, materials, diameters and main features of Jagwire cables. Our products are divided into four different kinds of systems which can be corresponded to a variety of different needs.

下圖主要說明Jagwire內線之產品組成構造、材質與相關主要特色。我們的產品區分為四種不同的系統，可對應到各種不同的需求。

TEFLON® ORIGINAL TRADEMARK

DuPont® has licensed the use of the Teflon® trademark to Jagwire.

TEFLON® 鐵氟龍為原廠註冊商標，為美國杜邦®公司正式授權Jagwire之商標使用權。

new

STS-LF

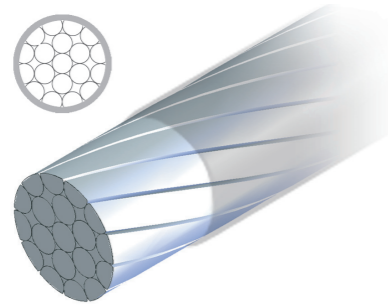

EXTRUDED CABLE SYSTEM 極致低摩擦內線系統

STS-LF (Low Friction, Stainless) 極致低摩擦內線

▲ Ultra-low friction cable with Speed Lube housing which provides rapid braking responsiveness and precise shifting. The best choice for the professional users.

超低摩擦係數，搭配Jagwir新全注油Speed Lube外殼，可提供快速回應煞車力/精準的變速，是專業性能的最佳首選

▲ Slick process: pre-stretches cable for maximum responsiveness

研磨程序:將內線預拉整直至最密合程度

▲ Stainless material: permanent rust-free performance

不銹鋼材質:長久不會有生鏽狀態發生

TEC™ / TEC-ST™

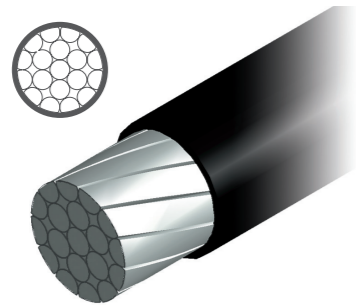

COATED CABLE SYSTEM 批覆內線系統

TEC (Teflon® coated) 鐵氟龍鍍鉍研磨內線

TEC-ST (Teflon® coated, Stainless) 鐵氟龍不銹鋼研磨內線

▲ Teflon® coating: friction-free, low-maintenance (easy clean) & eco-friendly for all-weather performance

鐵氟龍批覆:摩擦係數低、易保養(容易清潔)、環保特性可提供全天候使用。

▲ Slick process: pre-stretches cable for maximum responsiveness

研磨程序:將內線預拉整直至最密合程度

▲ Stainless material: permanent rust-free performance

不銹鋼材質:長久不會有生鏽狀態發生

GAS™ / STS™

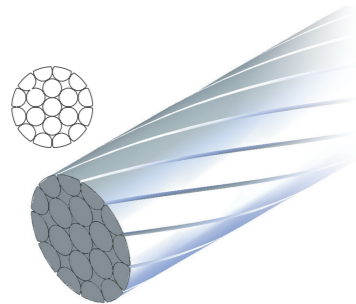

SLICK CABLE SYSTEM 研磨內線系統

GAS (Slick-Galvanized) 鍍鉍研磨內線

STS (Slick-Stainless) 不銹鋼研磨內線

▲ Smooth surface & low friction

表面光滑 & 低摩擦係數

▲ Pre-stretching can have more directly on the feedback off brake & precise shifting performance

內線已做預拉整直可讓煞車回饋更直接與更精準的變速

GAR™ / STR™

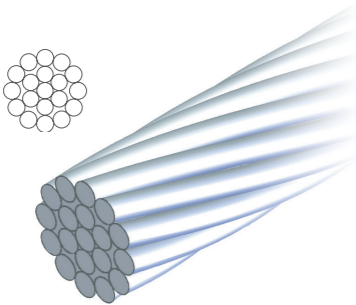

REGULAR CABLE SYSTEM 標準內線系統

GAR (Galvanized Steel) 鍍鉍內線

STR (Stainless Steel) 不銹鋼內線

Jagwire Weld Cutting & Cable Stopper

點焊裁切與線尾打花壓鑄技術

The photos compare the new method [left] with the previous [right]. The machine weld-cuts the cable with an electric current, causing the strands to fuse together, ensuring easy insertion of cables into housing. The machine then forms a temporary stopper (or flower) at nipple ends, ready for the die-casting mold. Weld cutting also prevents rust, as no acid treatment is required. Previously, after punch cutting, some strands tended to come loose, and removal of the tin coating with acid, prior to galvanizing, allowed rust to develop.

圖右為點焊裁切(左)與傳統裁切(右)之比較差異。內線在機器裁切時即以點焊方式收尾，可使內線尾端完整。在內線穿組外殼與零件時，穿組更容易並不易變形。裁切後，機器會在壓鑄鉗頭前於內線尾端打上一個暫時的花頭。此種裁切技術，會因為過程無酸性物質影響故不會造成生鏽情況產生。在傳統裁切過程中，於裁切完成後會很容易的將所有內線擠在線頭，並造成內線上的錫脫落，特別是材質普通的鋼線，而這些問題都會因為新的裁切技術而得到完美的解決。

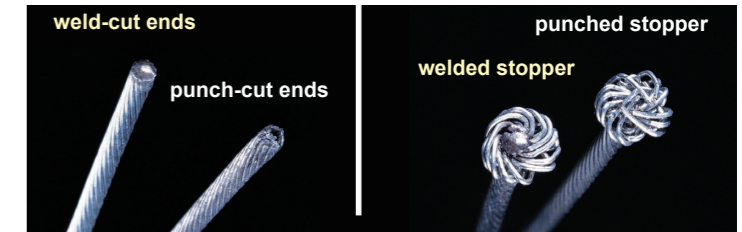

Cable Nipple Options 內線鉗頭規格

Nipples are die-cast onto cable ends for durability and strength, adding to rider safety and confidence. All nipple types are compatible with any required cable specifications.

內線尾端的鉗頭是由鉍水經過鑄造程序所完成的，耐久性與強度提供了更安全與更安心的騎乘條件。所有的鉗頭樣式皆能夠符合目前所有剎車與變速系統的需求。

Nipple	Description	Cable diameter	Nipple	Description	Cable diameter
--------	-------------	----------------	--------	-------------	----------------

Derailleur 變速

4.3*4.4

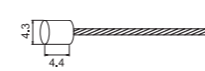

D01 (4.3*4.4) Shimano® & SRAM® shift system compatible 適用於Shimano® & SRAM® 變速系統

1.1 - 1.2mm

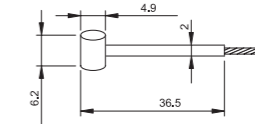

D03 Shimano® internal 3-Speed compatible 適用於Shimano®內三速變速系統

1.0mm

3.9*5

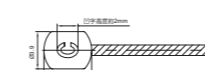

D02 (3.9*5) Campagnolo® shift system compatible 適用於Campagnolo®變速系統

1.1 - 1.2mm

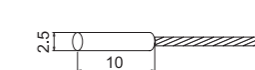

D04 Sturmey Acher® & SACHS® internal 3-speed compatible 適用於Sturmey Acher® & SACHS®內變速系統

1.0 - 1.2mm

Brake 煞車

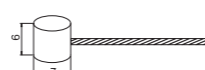

B02 (7*6) Shimano® & SRAM® MTB, BMX system compatible 適用於Shimano® & SRAM® 登山車, 表演車煞車系統

1.5 - 1.6mm

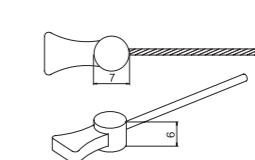

S02 W/ triangle holder 懸吊式內線鉗頭

1.6, 1.8 & 2.0mm

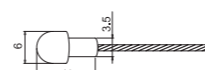

B04 (6*11) Shimano® & SRAM® Road System compatible 適用於Shimano® & SRAM® 公路車系統

1.5 - 1.6mm

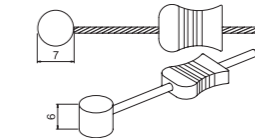

S04 w/ "loaf" holder 雙鉗頭懸吊式內線

1.6 & 1.8mm



B05 (5.5*11.6) Campagnolo® Road brake system compatible 適用於Campagnolo® 公路車煞車系統

1.5mm

Housing 外殼系列



Standard Series 標準系列

Brake 煞車

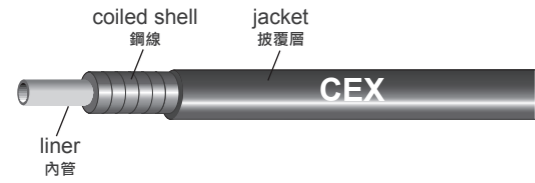

CEX™

- ▲ Low compression 低壓縮比
- ▲ Low-friction polymer liner 低摩擦塑膠內管
- ▲ Super-durable plastic layer, cold weather resistant 零下20度低溫使用可·超耐久外層披覆
- ▲ OD. 5mm available 適用外徑5mm

CGX™

- ▲ High carbon content steel and rigid structural design creates super-low compression ratio for maximum braking responsiveness 高碳鋼線搭配較強韌的結構設計提供了超低的壓縮比率·讓刹車的靈敏度提高·增加刹車的性能。
- ▲ OD. 5mm available 適用外徑5mm
- ▲ Slick-Lube specified 全順滑注油內管Liner為標準配備



Slick-Lube specified (Light Lubricated Liner) 全順滑注油內管

- ▲ Lubricant is specifically designed for long-life and is highly water resistant, consistent low friction performance. 潤滑油是專為長時間使用所設計的·具有高防水性與低摩擦係數的特色。
- ▲ Exceptional adhesive properties ensures the grease will stay in the liner 具特殊黏度特性是為了確保油品會持續留在管內不易流出

Derailleur 變速

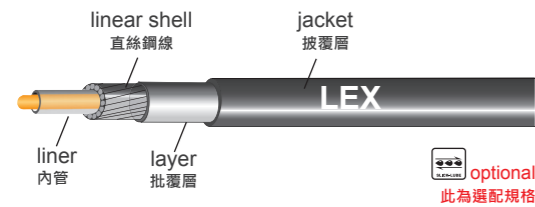
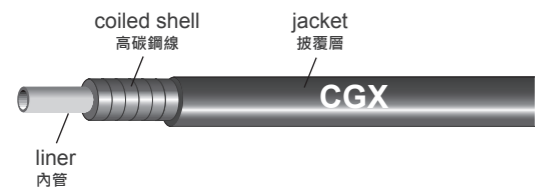

CGX™

- ▲ High carbon content steel and rigid structural design creates super-low compression ratio for precise shifting 高碳鋼線搭配較強韌的結構設計提供了超低的壓縮比率·讓變速的性能更加靈敏與準確。
- ▲ Shimano TOURNEY® derailleur system compatible Shimano TOURNEY® 變速系統適用
- ▲ OD. 4mm available 適用外徑4mm

LEX™

- ▲ Compressionless shell for precise shifting 直絲結構·零壓縮比·提供了更精準的變速反應
- ▲ Super light weight 重量較輕
- ▲ Double plastic layer for increased weatherproofing and durability 雙層披覆因應不同使用條件的耐久性
- ▲ OD. 4mm available 適用外徑4mm
- ▲ Slick-Lube optional 全順滑注油內管Liner為選配規格



Color options

可供選擇顏色



※# 09 Translucent available with 5mm in coiled type housing only.
09只提供5mm CEX環狀結構規格。
※#72 Chrome sliver available with 5mm CGX-SL and 5mm LEX-SL housing.
#72 高亮銀外殼規格只適用於5mm CGX-SL與5mm LEX-SL系列

Frozen Series 平光系列

Brake 煞車

CGX™

- ▲ High carbon content steel and structural design creates super-low compression ratio from maximum braking responsiveness 高碳鋼線搭配較強韌的結構設計提供了超低的壓縮比率·讓刹車的靈敏度提高·增加刹車的性能
- ▲ OD. 5mm available 適用外徑5mm
- ▲ Slick-Lube specified 全順滑注油內管Liner為標準規格

Color options 可供選擇顏色



ID-line 指示線系列

Brake 煞車

CGX™

- ▲ High carbon content steel and rigid structural design creates super-low compression ratio for maximum braking responsiveness 高碳鋼線搭配較強韌的結構設計提供了超低的壓縮比率·讓刹車的靈敏度提高·增加刹車的性能。
- ▲ OD. 5mm available 適用外徑5mm
- ▲ Slick-Lube specified 全順滑注油內管Liner為標準規格

Color options 可供選擇顏色



Derailleur 變速

LEX™

- ▲ Compressionless shell for precise shifting 直絲結構·零壓縮比·提供了更精準的變速反應
- ▲ Super light weight 重量較輕
- ▲ Double plastic layer for increased weatherproofing and durability 雙層披覆因應不同使用條件的耐久性
- ▲ OD. 4mm available 適用外徑4mm
- ▲ Slick-Lube specified 全順滑注油內管Liner為標準規格

Reflective Housing 反光系列

Brake 煞車

CEX™ / CGX™

- ▲ Reflective surface increase safety for night time riding 反光材質的表面增加了夜間騎乘時的安全性
- ▲ OD. 5mm available 適用外徑5mm
- ▲ Slick-Lube optional 全順滑注油內管Liner為選配規格

Color options 可供選擇顏色

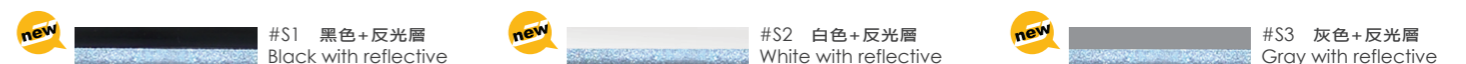

Braided Series 編織系列

Brake 煞車

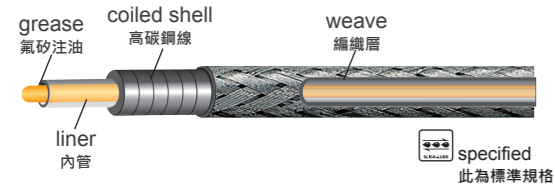

CGX™

- ▲ High carbon content steel and rigid structural design creates super-low compression ratio for maximum braking responsiveness
高碳鋼線結構搭配較強韌的結構設計提供了超低的壓縮比率，讓制車的靈敏度提高，增加制車的反應度。
- ▲ Hi-tech metallic look
高科技的金屬編織外觀
- ▲ O.D. 5mm available
適用外徑5mm
- ▲ Slick-Lube specified
全順滑注油內管Liner為標準搭配規格

Derailleur 變速

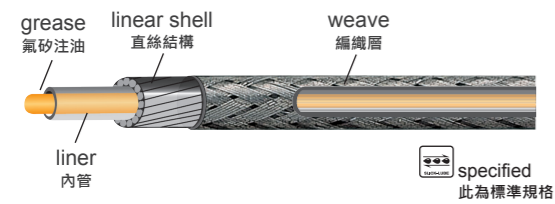

LEX™

- ▲ Compressionless shell for precise shifting
直絲結構，零壓縮比，提供了更精準的變速反應
- ▲ Super light weight
重量較輕
- ▲ Hi-tech metallic look
高科技的金屬編織外觀
- ▲ O.D. 4.5mm available
適用外徑4.5mm
- ▲ Slick-Lube specified
全順滑注油內管Liner為標準搭配規格

Color options 可供選擇顏色



Reinforced Series 強化編織系列

Brake 煞車

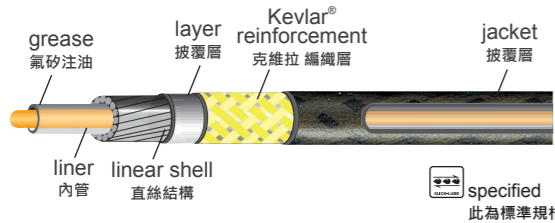

KEB™

- ▲ Kevlar® brand fiber reinforced with compressionless housing for super braking
Kevlar®(克維拉®)高性能纖維包裹直絲結構鋼線提供高性能煞車
- ▲ Ideal for cable-actuated disc brakes
機械式碟刹的最佳搭配首選
- ▲ Super light weight (30% less than standard coiled brake housing)
輕量化(較一般環狀外殼輕30%)
- ▲ Compatible with brake
適用於煞車系統
- ▲ Hi-tech look
高科技的外觀
- ▲ O.D. 5mm for brake
標準規格: 制車專用5mm
- ▲ Slick-Lube specified
全順滑注油內管Liner為標準搭配規格

CAUTION: Reinforced (linear shell) brake housing must be used with Jagwire specific lined alloy ferrules or POP adapters to ensure compressionless braking performance

注意: 直絲結構強化外殼使用於煞車線必須搭配Jagwire特殊襯裡鋁端套系列或POP端套系列已確保更完整的煞車性能。POP端套為V刹夾器彎管專門設計的

Color options 可供選擇顏色

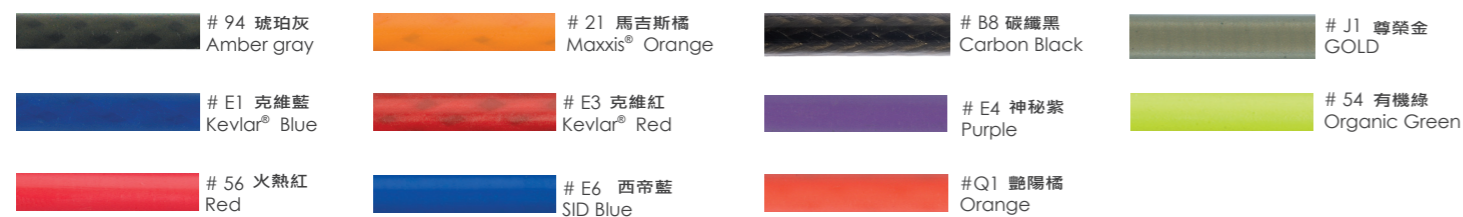

Accessories 配件



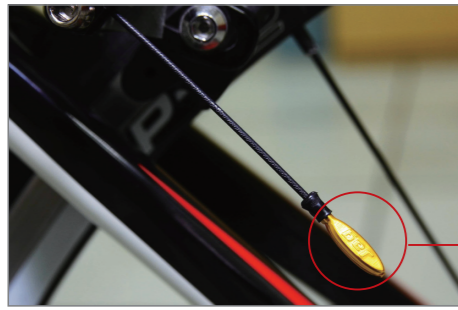

Cable Tips
線尾套系列

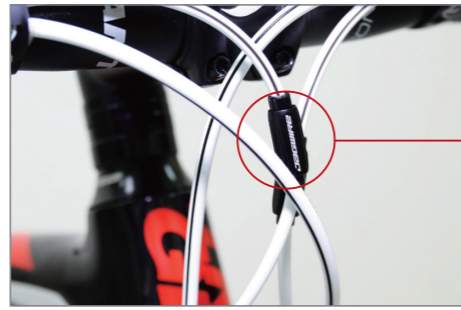

In-line Adjuster Barrel
同軸式調整螺絲

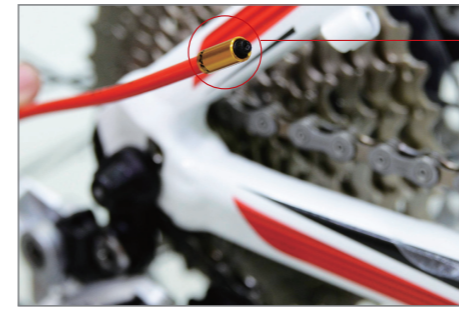

Cable Raincoat
防污泥端套組



Rotating Hook
導管集線器



Threaded Index Cable Boss
車架止栓轉接座
CC238A



Index Adjuster
定格調整螺絲
CM136B



Tube Tops
保護套

CCG017-BJ, CCG025-BJ



Stick-on Guide
自黏式導線座系列



Adjustable Cable Grip
止栓轉接座系列





Open End Cap for Shift Housing 變速用標準端套

Part No.	Description	Material / Finish		
 CC464BJ Black/黑色 CC464CJ CP/本色	Open End Cap, Fits 4mm Shifting housing (Recommended Use: SRAM® & Shimano® Shiffig System) 標準端套, 適用4mm變速外殼 (建議使用於SRAM® & Shimano®系統)	Alloy / Anodized 鋁/陽極		
 CC464OJ Gold/金色 CC464RJ Red/紅色				
 CC464SJ Silver/銀色 CC464UJ Blue/藍色				
 CC464EJ Cash Green/美金綠 CC464NJ Tango/橘色				
 CC115-4I Black/黑色			Open End Cap (CNC), Fits 4mm thicker design for better enforcement 標準端套(CNC車削), 適用4mm變速外殼· 前端加厚設計·強度增加	Brass / Zinc plated 銅/鍍鋅
 CC115-4F Black/黑色 CC115-4FS Silver/銀灰色			Open End Cap, Fits 4mm housing 標準端套, 適用4mm變速外殼	Plastic 塑膠
 CC191 Satin silver/銀色	Shift Lever Adapter, Fits 4mm housings, SACHS® 3-Speed compatible 變速手把轉接, 適用於4mm外殼和SACHS®內三速系統	Brass / Nickel plated 銅/鍍鎳		
 CM115-4N silver/銀色	Open End Cap (CNC), Fits 4.5mm Housing 標準端套(CNC), 適用4.5mm外殼	Brass / Nickel Plated Coating 銅/鍍鎳		
 CM115-4L Black/黑色	Open End Cap (CNC) Fit 4.5mm Housing 標準端套(CNC), 適用4.5mm外殼	Brass / Nickel Plated 銅 / 鍍鎳		





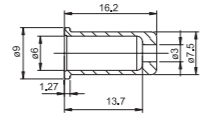

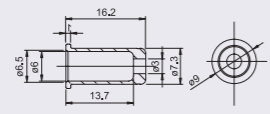



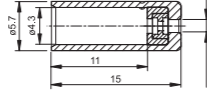







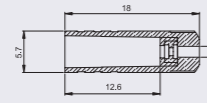

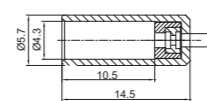
Open End Cap for Brake Housing 煞車用標準端套

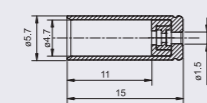
Part No.	Description	Material / Finish		
 CC715BJ Black/黑色 CC715CJ CP/本色	Open End Cap, Fits 5mm Brake housings 標準端套, 適用5mm煞車外殼	Alloy/Anodized 鋁/陽極		
 CC715OJ Gold/金色 CC715RJ Red/紅色				
 CC715SJ Silver/銀色 CC715UJ Blue/藍色				
 CC715EJ Cash Green/美金綠 CC715NJ Tango/橘色				
 CC115-3 Satin silver/銀色 CC115-3E Black/黑色			Open End Cap (CNC), Fits 5mm CEX, CGX 標準端套(CNC車削), 適用5mmCEX, CGX外殼· 前端加厚設計·強度增加	Brass / Nickel plated 銅/鍍鎳
 CC115-2D Satin silver/銀色 CC115-2DE Black/黑色			Non-Crimping End Cap, Fits 5mm CEX, CGX Taiwan Patent: 158536 爪式端套, 適用5mmCEX·CGX外殼 台灣專利:158536	Brass / Nickel plated 銅/鍍鎳
 CC115-2 Satin silver/銀色 CC115-2E Black/黑色	Open End Cap, Fits 5mm CEX, CGX 標準端套, 適用5mmCEX·CGX外殼	Brass / Nickel plated 銅/鍍鎳		
 CC115-6 Satin silver/銀色 CC115-6B Black/黑色	Cable stop adapter, Converts 4mm Stopper to fit with 5mm Housing. 外殼轉接端套, 適用於4mm止栓轉換成5mm外殼	Brass / Nickel plated 銅/鍍鎳		
 CC115-7 Satin silver/銀色	Shifting Lever Adapter, Fits 5mm Housings, Sturmey Archer® 3-Speed cable set compatible 變速手把轉接端套,適用5mm外殼· 用於Sturmey Archer®內三速系統	Brass / Nickel plated 銅/鍍鎳		
 CC193 Black/黑色	Open End Cap, Fits 5mm housings 標準端套, 適用於5mm外殼	Plastic 塑膠		

Open End Cap 其他標準端套





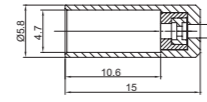





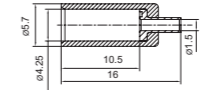





Part No.	Description	Material / Finish
 CC307 Black/黑色	 Open End Cap, Fits 6mm housing to 7.5mm end 轉換端套, 適用6mm外殼轉換成7.5mm外殼	Alloy / Anodized 鋁/陽極
 CC307-A Black/黑色	 Open End Cap, Fits 6mm housing to 7.3mm end 轉換端套, 適用6mm外殼轉換成7.3mm外殼	Alloy / Anodized 鋁/陽極

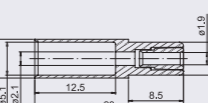

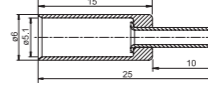

Sealed End Cap for shift Housing 變速用油封端套

Part No.	Description	Material / Finish
 CM176BJ Black/黑色	 Sealed End Cap, Fits 4mm LEX housing 油封端套, 適用4mm LEX變速外殼	Alloy / Anodized 鋁/陽極
 CM176OJ Gold/金色	 Sealed End Cap, Fits 4mm LEX housing 油封端套, 適用4mm LEX變速外殼	Alloy / Anodized 鋁/陽極
 CM176RJ Red/紅色		
 CM176SJ Silver/銀色		
 CM176UJ Blue/藍色		
 CM176EJ Cash Green/美金綠		
 CM176NJ Tango/橘色		
 CM007 Black/黑色	 Sealed End Cap, Fits 4mm LEX housing 油封端套, 適用4mm LEX變速外殼	Plastic 塑膠
 CM007S Silver/銀灰色		
 CM207-A Black/黑色	 Sealed End Cap, Fits 4mm housing 油封端套, 適用於4mm外殼	Brass / Zinc plated 銅/鍍鋅
 CM174BJ Black/黑色	 Sealed End Cap, Fits 4.5mm housing 油封端套, 適用於4.5mm外殼	Alloy / Anodized 鋁/陽極
 CM174OJ Gold/金色		
 CM174RJ Red/紅色		
 CM174SJ Silver/銀色		
 CM174UJ Blue/藍色		
 CM174EJ Cash Green/美金綠		
 CM174NJ Tango/橘色		
 CM208-A Black/黑色	 Sealed End Cap, Fits 4.5mm housing 油封端套, 適用於4.5mm外殼	Brass / Zinc plated 銅/鍍鋅

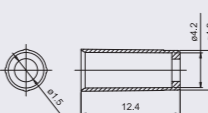

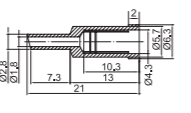

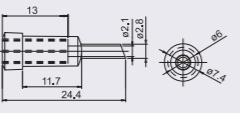

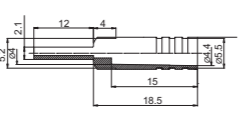



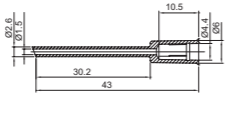

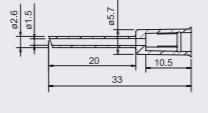

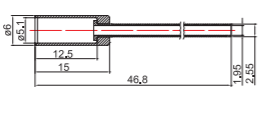
Lined End Caps 襯裡端套

Part No.	Description	Material / Finish
 CM251BJ Black/黑色	 Short Nosed End Cap Fits 4mm housing 短鼠尾端套, 4mm外殼使用	Alloy / Anodized / POM 鋁/陽極/塑鋼
 CM251OJ Gold/金色	 Lined End Cap, Fits 5mm Housing, designed specially for KEB® brake housing to work with a standard guide pipes and adjusters with a smaller inner diameter. 適用5mm外殼, 專為KEB外殼設計, 內縮設計剛好可放置於夾器內彎管	Alloy / Anodized 鋁/陽極
 CM251RJ Red/紅色		
 CM251SJ Silver/銀色		
 CM251UJ Blue/藍色		
 CM251EJ Cash Green/美金綠		
 CM251NJ Tango/橘色		
 CM029BJ Black/黑色	 Lined End Cap, Fits 5mm Brake housings, built-out polymer nose, prevents abrasion of coated cables and reduces friction 襯裡端套, 適用5mm剎車外殼, 防止刮傷內線批覆層並減少摩擦	Alloy/Anodized 鋁/陽極
 CM029SJ Silver/銀色		
 CM173BJ Black/黑色	 End Cap Adaptor, Converts 5mm End Cap to fit 4mm housing 端套內襯, 轉換5mm端套為4mm端套	Polymer 塑膠
 CM173OJ Gold/金色		
 CM173RJ Red/紅色		
 CM173SJ Silver/銀色		
 CM173UJ Blue/藍色		
 CM173EJ Cash Green/美金綠		
 CC192-6 Black/黑色	 End Cap Adaptor, Converts 5mm End Cap to fit 4mm housing 端套內襯, 轉換5mm端套為4mm端套	Polymer 塑膠





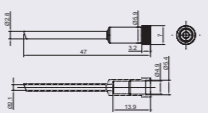

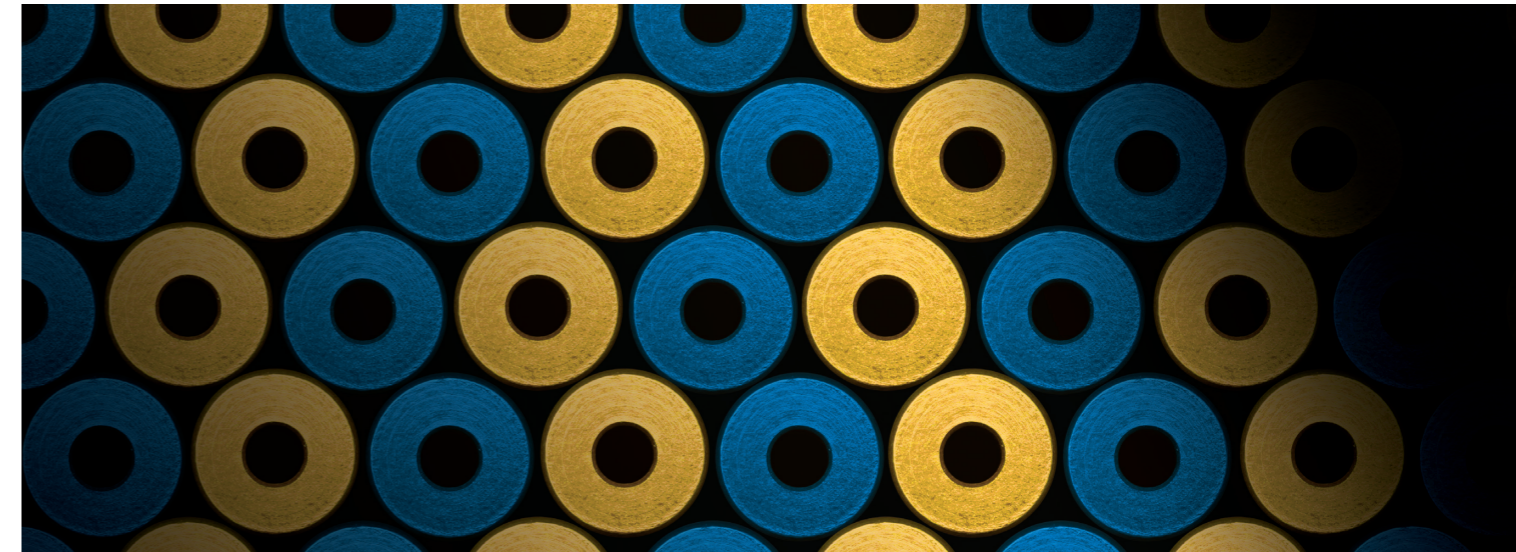



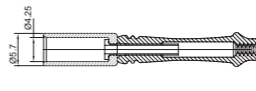



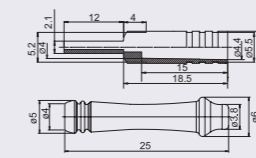

Part No.	Description	Material / Finish
 CC115-4A Black/黑色	 Lined End Cap, Fits 4mm housings 襯裡端套, 適用於4mm外殼	Plastic/Black 塑膠/黑色
 CC193-1 Black/黑色	 Lined End Cap, Fits 5mm housings 襯裡端套, 適用於5mm外殼	Plastic 塑膠
 CC115-4J Black/黑色	 Lined End Cap, Fits 4mm housings 襯裡端套, 適用於4mm外殼	Plastic / Black 塑膠/黑色

Nose End Cap 襯裡端套

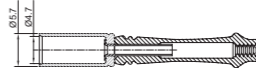
Part No.	Description	Material / Finish			
 CC115-4C Black/黑色	 Nosed End Cap, Fits 4mm housings 鼠尾端套, 適用於4mm外殼	Plastic / Black 塑膠/黑色			
 CC115-4G Black/黑色	 Nosed End Cap, Fits 4mm housings 鼠尾端套, 適用於4mm外殼	Plastic / Black 塑膠/黑色			
 CM199BJ Black/黑色	 Nosed End Cap, Fits 5mm Brake housing 鼠尾端套, 適用5mm剎車外殼	Alloy / Anodized 鋁/陽極			
 CM199OJ Gold/金色	 CM199RJ Red/紅色	 CM199SJ Silver/銀色	 CM199UJ Blue/藍色	 CM199EJ Cash Green/美金綠	 CM199NJ Tango/橘色
 CC193-3 Black/黑色	 Nosed End Cap, Fits 5mm housings 鼠尾端套, 適用於5mm外殼	Plastic / Black 塑膠/黑色			



Dirt Guard 防汙泥端套組

Part No.	Description	Material / Finish			
 CM261BJ Black/黑色	 Dirt Guard Kit, Fits 4mm Shifting housing, Prevent dust from entering the housing 防汙泥端套組, 適用4mm變速外殼, 防止汙泥進入外殼	Alloy / Anodized Silicon Gel / Black 鋁/陽極 矽膠/黑色			
 CM261OJ Gold/金色	 CM261RJ Red/紅色	 CM261SJ Silver/銀色	 CM261UJ Blue/藍色	 CM261EJ Cash Green/美金綠	 CM261NJ Tango/橘色
 CM276 Black/黑色	 Dirt Guard Kits, Fits 4mm housing, Prevent dust from entering the housing 防汙泥端套組, 適用於4mm外殼,防止汙泥進入外殼	Plastic / Silicon / Black 塑膠/矽膠/黑色			
 CM262BJ Black/黑色	 Dirt Guard Kit, Fits 4.5mm Shifting housing, Prevent dust from entering the housing 防汙泥端套組, 適用4.5mm變速外殼, 防止汙泥進入外殼	Alloy / Anodized Silicon Gel / Black 鋁/陽極 矽膠/黑色			
 CM262OJ Gold/金色	 CM262RJ Red/紅色	 CM262SJ Silver/銀色	 CM262UJ Blue/藍色	 CM262EJ Cash Green/美金綠	 CM262NJ Tango/橘色

Hooded End Cap 防汙泥端套(精實版)

Part No.	Description	Material / Finish
CM2600J Gold/金色	Hooded End Cap Fits 4mm Shifting housing. An Extra layer of protection against dirt 防汙泥端套(精實版) 適用於4mm外殼 增加結構防止髒汙進入	Alloy/ Anodized/Gold NBR / Black 鋁/陽極/金色 橡膠/黑色
new CM260BJ Black/黑色	Hooded End Cap Fits 4mm Shifting housing. An Extra layer of protection against dirt 防汙泥端套(精實版) 適用於4mm外殼 增加結構防止髒汙進入	Alloy/Anodized/Black NBR/Black 鋁/陽極/黑色 橡膠/黑色
CM2710J Gold/金色	Hooded End Cap Fits 4.5mm Shifting housing. An Extra layer of protection against dirt 防汙泥端套(精實版) 適用於4.5mm外殼 增加結構防止髒汙進入	Alloy/ Anodized/Gold NBR / Black 鋁/陽極/金色 橡膠/黑色
new CM271BJ Black/黑色	Hooded End Cap Fits 4.5mm Shifting housing. An Extra layer of protection against dirt 防汙泥端套(精實版) 適用於4.5mm外殼 增加結構防止髒汙進入	Alloy/Anodized/Black NBR/Black 鋁/陽極/黑色 橡膠/黑色
CM2690J Gold/金色	Hooded End Cap Fits 5.0mm brake housing. An Extra layer of protection against dirt 防汙泥端套(精實版) 適用於5mm外殼 增加結構防止髒汙進入	Alloy/ Anodized/Gold NBR / Black 鋁/陽極/金色 橡膠/黑色
new CM269BJ Black/黑色	Hooded End Cap Fits 5.0mm brake housing. An Extra layer of protection against dirt 防汙泥端套(精實版) 適用於5mm外殼 增加結構防止髒汙進入	Alloy/ Anodized/Black NBR / Black 鋁/陽極/黑色 橡膠/黑色

Folding-bike End Cap 小折專用端套系列 To prevent housing damage when bicycle is folded



Part No.	Description	Material / Finish
new CC976 Black/黑色	Anti-kink End Cap Fits 4mm Housing 防折端套 適用於4mm外殼	Plastic/Black 塑膠/黑色
new CC977 Black/黑色	Anti-kink End Cap Fits 4.5mm Housing 防折端套 適用於4.5mm外殼	Plastic / Black 塑膠/黑色
new CC978 Black/黑色	Anti-kink End Cap Fits 5mm Housing 防折端套 適用於5mm外殼	Plastic / Black 塑膠/黑色

Other 其他零件

Part No.	Description	Material / Finish
CM143	Rotating Hook, Fits 4mm & 5mm housings 導管集線器, 適用於4、5mm外殼	Plastic/Black 塑膠/黑色
CM143W	Rotating Hook, Fits 4mm & 5mm housings 導管集線器, 適用於4、5mm外殼	Plastic/White 塑膠/白色
CC115-9	S Housing Holder, Fits 4 & 5mm housings S型導管集線器, 適用於4、5mm外殼	Plastic/Black 塑膠/黑色
CC333-1	Housing Holder, Fits V-Brake 導管集線器, 適用於V型夾器後剎端	Plastic/Black 塑膠/黑色
CC115-4D	Dirt Guard 橡膠防塵套	Silicon Gel/Black 矽膠/黑色
CC231B	Dirt Guard Fits 5mm Brake Nosed End Cap. 橡膠防塵套 適用5mm剎車鼠尾端套	Silicon Gel/Black 矽膠/黑色
CC231S	Dirt Guard Fits 5mm Brake Nosed End Cap. 橡膠防塵套 適用5mm剎車鼠尾端套	Silicon Gel/Silver 矽膠/銀色
CCG004QBG	Dirt Guard Fits 4 & 4.5mm Nosed End Cap 橡膠防塵套, 適用4、4.5mm鼠尾端套	Silicon Gel/Black 矽膠/黑色
CCG004QGG	Dirt Guard Fits 4 & 4.5mm Nosed End Cap 橡膠防塵套, 適用4、4.5mm鼠尾端套	Silicon Gel/Silver 矽膠/銀色
CCG014B	Dirt Guard, Fits 4mm & 4.5mm Nosed End Cap 外殼防水套, 適用於4mm、4.5mm鼠尾端套	Silicon Gel/Black 矽膠/黑色
CCG014R	Dirt Guard, Fits 4mm & 4.5mm Nosed End Cap 外殼防水套, 適用於4mm、4.5mm鼠尾端套	Silicon Gel/Red 矽膠/紅色

Tube Tops 保護套系列

Part No.	Description	Material / Finish
CCG017-BJ	  <p>Tube Tops 3G™ Frame Protector, Fits 4, 4.5 & 5mm housing Clamp Type</p> <p>3G C型扣式車架保護套, 適用於4、4.5、5mm外殼</p>	TPR/Black Black logo TPR橡膠/黑色
CCG017-WJ	  <p>Tube Tops 3G™ Frame Protector, Fits 4, 4.5 & 5mm housing Clamp Type</p> <p>3G C型扣式車架保護套, 適用於4、4.5、5mm外殼</p>	TPR/White White logo TPR橡膠/白色
CCG025-BJ	  <p>Tube Tops 3G™ Frame Protector, Fits 5.5mm housing, Clamp Type</p> <p>3G C型扣式車架保護套, 適用於5.5mm外殼</p>	TPR/Black Black logo TPR橡膠/黑色
CCG025-WJ	  <p>Tube Tops 3G™ Frame Protector, Fits 5.5mm housing, Clamp Type</p> <p>3G C型扣式車架保護套, 適用於5.5mm外殼</p>	TPR/White White logo TPR橡膠/白色
CCG037	  <p>Tube Tops 4G, Frame Protector, Fit 4, 4.5 & 5mm housing, Slide type</p> <p>4G車架保護套, 套入方式組裝, 適用於4、4.5、5mm外殼</p>	Silicon Gel/Black Yellow logo 矽膠/黑色 黃色Logo
CCG043BJY	  <p>Tube Tops™ Frame Protector, Fits 4, 4.5 & 5mm Frame, Slide type.</p> <p>車架保護套, 以套入方式組裝, 適用於4、4.5、5mm外殼</p>	Silicon gel/Black Yellow logo 矽膠/黑色 黃色Logo
CCG043TJS	  <p>Tube Tops™ Frame Protector, Fits 4, 4.5 & 5mm Frame, Slide type.</p> <p>車架保護套, 以套入方式組裝, 適用於4、4.5、5mm外殼</p>	Silicon gel/ Translucent Silver logo 矽膠/ 透明 灰色Logo
CCG052B	  <p>Mini Tube Tops™ Frame Protector, Fits 4, 4.5 & 5mm housings, Slide type,</p> <p>迷你型車架保護套, 以套入方式組裝, 適用於4、4.5、5mm外殼</p>	Silicon Gel Black 矽膠/黑色
CCG052T	  <p>Mini Tube Tops™ Frame Protector, Fits 4, 4.5 & 5mm housings, Slide type,</p> <p>迷你型車架保護套, 以套入方式組裝, 適用於4、4.5、5mm外殼</p>	Silicon Gel Translucent 矽膠/半透明
CCG052R	  <p>Mini Tube Tops™ Frame Protector, Fits 4, 4.5 & 5mm housings, Slide type,</p> <p>迷你型車架保護套, 以套入方式組裝, 適用於4、4.5、5mm外殼</p>	Silicon Gel Red 矽膠/紅色

Frame Parts 車架零件

Part No.	Description	Material / Finish
CC182	  <p>Internal Cable Stop 車架用半通止栓</p>	Brass / Nickel Plated Satin silver 銅/鍍銀/銀色
CC238A	  <p>M5 Threaded Index Boss, down tube location recommended M5螺紋止栓, 車架下管用止栓</p>	Alloy #6061 鋁#6061/本色
CC238A-1	  <p>M5 Threaded Index Boss, down tube location recommended M5螺紋止栓, 車架下管用止栓</p>	Alloy #6061 鋁#6061/本色
CC238A-2	  <p>M5 Threaded Index Boss, down tube location recommended M5螺紋止栓, 車架下管用止栓</p>	Alloy #6061 鋁#6061/本色
CC238D-1	  <p>M5 Threaded Index Boss, down tube location recommended M5螺紋止栓, 車架下管用止栓</p>	Alloy #6061 鋁#6061/本色
CC238D-2	  <p>M5 Threaded Index Boss, down tube location recommended M5螺紋止栓, 車架下管用止栓</p>	Alloy #6061 鋁#6061/本色

Frame Parts 車架零件

Part No.	Description	Material / Finish
CC295	Pivot plug - M8, Fits Fork Pivot M8前叉剎車座螺絲	Plastic / Black 塑膠/黑色
CC295-1	Pivot plug - M10, Fits Frame Pivot M10車架剎車座螺絲	Plastic / Black 塑膠/黑色
CC360	Pivot plug - M8, Fits Fork Pivot M8前叉剎車座螺絲	Stan silver/Chrome Plated 不鏽鋼/本色
CC361	Pivot plug - M10, Fits Frame Pivot M10車架剎車座螺絲	Stan silver/Chrome Plated 不鏽鋼/本色
CC359	Housing/Hose Guide Fits Frame Loops 5.5mm 車架止栓導管座, 適用於5.5mm外殼	Plastic / Black 塑膠/黑色
CC359-1	Housing/Hose Guide Fits Frame Loops 5mm 車架止栓導管座, 適用於5mm外殼	Plastic / Black 塑膠/黑色
CC359-2	Housing/Hose Guide Fits Frame Loops 4.5 & 4mm 車架止栓導管座, 適用於4.5、4mm外殼	Plastic / Black 塑膠/黑色
CC359-4	Housing/Hose Guide one side Fits Frame Loops 4.5&4mm 車架只栓導管座,單邊 適用於4.5、4mm外殼	Plastic / Black 塑膠/黑色
CC270-1	Housing/Hose guide frame loop Fits 4, 4.5 & 5mm housings 車架止栓導管座,適用4、5mm外殼	Plastic / Black 塑膠/黑色
CC362	Internal Cable Stop 車架用半通止栓	Steel / Nickel plated / Satin silver 鐵/鍍銀/銀色
CC362-B	Internal Cable stop 車架用半通止栓	Steel/ Nickel Plated/ Black 鐵/鍍銀/黑色
CC362-B1	Internal Cable stop 車架用半通止栓	Steel/ Nickel plated / Black 鐵/鍍銀/黑色

Frame Parts 車架零件

Part No.	Description	Material / Finish
CC380	Cable Stopper Fits 5mm Housing 車架止栓 適用於5mm外殼	Alloy/Anodized/Black 鋁/陽極/黑色
CC380-1	Cable Stopper Fits 5mm Housing 車架止栓 適用於5mm外殼	Alloy/Anodized/Black 鋁/陽極/黑色
CCF048AB	Cable Stopper Fits 5mm Housing 車架止栓 適用於5mm外殼	Alloy/Anodized/Black 鋁/陽極/黑色
CM017-2	Cable Grip, Adjustable Clamps, Fits 4 - 6mm Housings 止栓轉接座(可調式), 適用4~6mm外殼	Stainless steel / Satin silver 不鏽鋼/銀色
CM017B	Cable Grip, Fits 5.0~5.5mm housings 止栓轉接座(固定式), 適用5~5.5mm外殼	Alloy / Black 鋁/黑色
CM017S	Cable Grip, Fits 5.0~5.5mm housings 止栓轉接座(固定式), 適用5~5.5mm外殼	Alloy / Silver 鋁/銀色
CM063	EZ-bend super-flexible housing segment is designed for easy set-up of Kevlar® reinforced compressionless housings on road bike handlebars 公路車手把專用導線連結彎管· 搭配KEB輕量化外殼專用	Steel W/Alloy End Tips 透明外殼/鋁端套
CME011	Stick-on Cable Guide, 3M adhesive attached 塑膠導線座, 3M背膠設計	Plastic / Black 塑膠/黑色
CME013B	Alloy Stick-on Cable Guide, 3M adhesive attached 鋁合金導線座, 3M背膠設計	Alloy / Black 鋁/黑色
CME013S	Alloy Stick-on Cable Guide, 3M adhesive attached 鋁合金導線座, 3M背膠設計	Alloy / Silver 鋁/銀色
CCZ021PB	C Clip Frame Loop Housing Guide C型車架止栓專用外殼扣環	Plastic/Black 尼龍/黑色

Frame Parts 車架零件





Part No.	Description	Material / Finish
CCN007NB	Plug for Internal Frame Routing SHIMANO Di2 車架止栓/剖溝保護套 適用SHIMANO Di2	NBR / Black 橡膠/黑色
CCN007NB-1	Plug for Internal Frame Routing 4mm Derailleur Housing 車架止栓/剖溝保護套 適用4mm變速外殼	NBR / Black 橡膠/黑色
CCN007NB-2	Plug for Internal Frame Routing 5mm Brake Housing 車架止栓/剖溝保護套 適用5mm煞車外殼	NBR / Black 橡膠/黑色
CCN007NB-3	Plug for Internal Frame Routing SHIMANO Ultegra Di2 車架止栓/剖溝保護套 適用SHIMANO Ultegra Di2	NBR / Black 橡膠/黑色
 CCN027-1	Plug for Internal Frame Routing 5mm Brake Housing 車架止栓/剖溝保護套 適用5mm煞車外殼	NBR/ Black 橡膠/黑色
 CCN027-3	Plug for Internal Frame Routing 4mm Derailleur Housing 車架止栓/剖溝保護套 適用4mm變速外殼	NBR/ Black 橡膠/黑色
 CCN027-5	Plug for Internal Frame Routing SHIMANO Di2 車架止栓/剖溝保護套 適用SHIMANO Di2	NBR/ Black 橡膠/黑色
CCN009	Plug for Internal Frame Routing For Close type 車架止栓保護套 適用於無孔徑	EPDM / Black 橡膠/黑色
CCN009-1	Plug for Internal Frame Routing SHIMANO Di2 車架止栓/剖溝保護套 適用SHIMANO Di2	EPDM / Black 橡膠/黑色

Cable Tips 線尾套系列





Part No.	Description	Material / Finish
CC117-A	Cable Crimps, Fits 1.0 - 1.2mm cables, Open type 內線尾套, 適用1.0 - 1.2mm線徑 (變速內線適用)	Alloy / Anodized 鋁/陽極
CC117-AO	Gold/金色	
CC117-AB	Black/黑色	
CC117-A06	Red/紅色	
CC117-B	Cable Crimps, Fit 1.0 - 1.8mm cables, Open type For Brake and shifting system 內線尾套, 適用1.0 - 1.8mm線徑 (剎車、變速內線適用)	Alloy / Anodized 鋁/陽極
CC117-C	Silver/銀色	
CC117-CO	Gold/金色	
CC117-C06	Red/紅色	
CC117-C07	Black/黑色	
CC117-C08	Blue/藍色	
CC117-C24	Pink/粉紅色	
CC117-C61	Cash Green/綠色	
CC117-C68	Purple/紫色	
CC117-CJ6	Tango/橘色	
CC117-D	Cable Crimps, Fit 1.0 - 1.8mm cables, Open type For Brake and shifting system 內線尾套, 適用1.0 - 1.8mm線徑 (剎車、變速內線適用)	Alloy / Anodized 鋁/陽極
CC117-PG	Twist On, Fit All Size Cables 內線尾套, 適用所有線徑內線 (可重複使用)	Plastic 塑膠



Non-Crimp 小天使系列

Part No.	Description	Material / Finish
 CM7430J Gold/金色	Re-useable For Brake and Shifting system • 可重複使用 • 適用於煞車及變速內線	NBR / Alloy / Anodized 橡膠/鋁/陽極
 CM743SJ Silver/銀色		
 CM743BJ Black/黑色		
 CM743RJ Red/紅色		

Cable Donuts 防刮墊圈系列

Part No.	Description	Material / Finish
 CC170-B	Cable Donuts, Fit 1.1 - 1.2mm cables, Octagonal Shape O型環-八角形狀(內線防刮墊圈), 適用1.1 - 1.2mm線徑(變速內線)	Polymer / Black 橡膠/黑色
 CC170-C	Cable Donuts, Fit 1.1 - 1.2mm cables, Octagonal Shape O型環-八角形狀(內線防刮墊圈), 適用1.1 - 1.2mm線徑(變速內線)	Polymer / Translucent 橡膠/透明
 CC170-BO	Cable Donuts, Fit 1.1 - 1.2mm cables, Round shape O型環-圓形形狀(內線防刮墊圈), 適用1.1 - 1.2mm線徑(變速內線)	Polymer / Black 橡膠/黑色
 CC170-CO	Cable Donuts, Fit 1.1 - 1.2mm cables, Round shape O型環-圓形形狀(內線防刮墊圈), 適用1.1 - 1.2mm線徑(變速內線)	Polymer / Translucent 橡膠/透明
 CC171-B	Cable Donuts, Fit 1.1 - 1.8mm cables, Octagonal Shape O型環-八角形狀(內線防刮墊圈), 適用1.1 - 1.8mm線徑(剎車內線)	Polymer / Black 橡膠/黑色
 CC171-C	Cable Donuts, Fit 1.1 - 1.8mm cables, Octagonal Shape O型環-八角形狀(內線防刮墊圈), 適用1.1 - 1.8mm線徑(剎車內線)	Polymer / Translucent 橡膠/透明
 CC171-BO	Cable Donuts, Fit 1.1 - 1.8mm cables, Round Shape O型環-圓形(內線防刮墊圈), 適用1.1 - 1.8mm線徑(剎車內線)	Polymer / Black 橡膠/黑色
 CC171-CO	Cable Donuts, Fit 1.1 - 1.8mm cables, Round Shape O型環-圓形(內線防刮墊圈), 適用1.1 - 1.8mm線徑(剎車內線)	Polymer / Translucent 橡膠/透明
 CC339-1	Eye End, Fits under 1.6mm cables 鋁束套 適用於1.6線徑	Alloy 鋁/本色

Cable/Housing Parts 內線/外殼零件

Part No.	Description	Material / Finish
CC40020	 <p>Cable Crimps, Fit 1.8mm or smaller cables, W/Cross end screw</p> <p>線止螺絲組 · 適用於1.8mm線徑或更小線徑 · 附十字型的螺絲</p>	Brass 銅/本色
CC112-6	 <p>Lever Adapter (CNC), Fits city bike caliper brakes</p> <p>外殼轉接端套(CNC) · 城市車專用</p>	Brass / Nickel plated / Satin silver 銅/鍍銀/銀色
CC114	 <p>Lever Adapter, universal type</p> <p>外殼轉接端套 · 通用型</p>	Alloy / Anodized / Silver 鋁/電鍍/銀色
CC126-1	 <p>M5 Cable Crimps, Side-pull brake compatible</p> <p>固定螺絲5mm · 煞車夾器用</p>	Steel / Argon plated / Silver 鐵/鍍氬/銀色
CC126-2	 <p>M6 Cable Crimps, Side-Pull brake compatible</p> <p>固定螺絲6mm · 煞車夾器用</p>	Steel / Argon plated / Silver 鐵/鍍氬/銀色
CC729SJ	 <p>Double-Ended Housing Connector 4.0 mm Derailleur Housing</p> <p>雙邊外殼導引端套 4.0mm變速外殼</p>	Alloy / Silver 鋁合金/銀色
CC728SJ	 <p>Double-Ended Housing Connector 4.5 mm Derailleur Housing</p> <p>雙邊外殼導引端套 4.5mm變速外殼</p>	Alloy / Silver 鋁合金/銀色
CC328AS-J	 <p>Double-Ended Housing Connector 5.0mm Brake housing</p> <p>雙邊外殼導引端套 5.0mm煞車外殼</p>	Alloy / Silver 鋁合金/銀色

Part No.	Description	Material / Finish
CC128-07	 <p>Cable Hanger Fits Canti Brakes</p> <p>吊線座含內管 · 煞車夾器用</p>	Aluminum / Black 鋁/黑色
CCG044B	 <p>V-Brake Pipe Boot V剎導管專用保護套</p>	Rubber / Black 橡膠/黑色
CC198	 <p>V-brake pipe boot V剎導管專用保護套</p>	Rubber / Black 橡膠/黑色
CC220A	 <p>Guide Pipe 82.5° 煞車器彎管82.5°</p>	Stainless steel tube w/ alloy end cap 不鏽鋼導管/鋁端套
CC221A	 <p>Guide Pipe 90° 煞車器彎管90°</p>	Stainless steel tube w/ alloy end cap 不鏽鋼導管/鋁端套
CC221T	 <p>Guide Pipe 90° 煞車器彎管90°</p>	Stainless steel tube w/ stainless end cap 不鏽鋼導管/不鏽鋼端套

Part No.	Description	Material / Finish
CC222A	Guide pipe 110° 煞車器彎管110°	Stainless steel tube w/ alloy end cap 不鏽鋼導管/鋁端套
CC222T	Guide pipe 110° 煞車器彎管110°	Stainless steel tube w/ stainless end cap 不鏽鋼導管/不鏽鋼端套
CC223A	Guide pipe 135° 煞車器彎管135°	Stainless steel tube w/ alloy end cap 不鏽鋼導管/鋁端套
CC401-2	Guide pipe, 0~180° flexible 自由式煞車器彎管0°~180°	Stainless steel tube w/ alloy end cap 不鏽鋼導管/鋁端套
CMD021B3	POP guide pipe 90°, alloy end tips (designed specially for Kevlar® reinforced cable housing) POP煞車器彎管90°鋁端套,克維拉(Kevlar)外殼專用	Stainless steel tube w/brass end cap 不鏽鋼管/不鏽鋼端套
CMD022B3	POP guide pipe 110°, alloy end tips (designed specially for Kevlar® reinforced cable housing) POP煞車器彎管110°鋁端套,KEB輕量化外殼專用	Stainless steel tube w/ brass end cap 不鏽鋼管/不鏽鋼端套
CMD221SO	Adjuster guide pipe 90° alloy end tips 90°鋁端頭轉接彎管 (內含彈簧緩衝結構)	Stainless steel tube w/ alloy end cap 不鏽鋼管/鋁端套

Part No.	Description	Material / Finish
CC119-2	M3.5 threaded cable connection, Sturmey Archer shifting cable set compatible M3.5車牙內線連結器·適用於Sturmey Archer內變速器使用·	Brass / Nickel plated / Satin Silver 銅/鍍銀/不銹鋼銀
CC122	M6 threaded bolt, 8.5x6.2mm head M6調整螺絲·前段內徑6.2mm外徑8.5 變速手把用	Steel / Argon plated / Silver 鐵/鍍氬/銀色
CC122-10	M6 threaded bolt, 8.5x6.2mm head M6調整螺絲·前段內徑6.2mm外徑8.5 變速手把用	Steel / Argon plated / Silver 鐵/鍍氬/銀色
CC122-8	M5 threaded bolt, 8.3x6.0mm head M5調整螺絲·前段內徑6.0mm外徑8.3 變速手把用	Steel / Argon plated / Silver 鐵/鍍氬/銀色
CC122T	M6 threaded bolt, 8.5x6.2mm head, built-in liner to prevent abrasion and reduces friction M6調整螺絲·前段內徑6.2mm外徑8.5·襯裡為外掛可防止、減少摩擦	Steel / Argon plated / Silver 鐵/鍍氬/銀色
CC142	M7 lever adjuster M7調整螺絲·煞車手把用	Steel / Nickel plated / Satin silver 鐵/鍍銀/不銹鋼銀
CC142-1	M7 lever adjuster M7調整螺絲·煞車手把用	Alloy / Anodized / Silver 鐵/電鍍/銀
CC159	M10 lever adjuster M10調整螺絲/煞車手把用	Alloy / Anodized / Silver bolt w/ black nut 鋁/陽極/銀色+黑色

Part No.	Description	Material / Finish
CC233	Mickey adjusting barrel, extra adjustment at cable stops 米老鼠車架止栓用調整螺絲	Steel / Chrome plated / Satin silver 鐵/鍍銅/電鍍銀
CC304	M5 threaded bolt, 9.0x6.0mm head M5螺絲 · 頭部內徑6mm外徑9mm	Alloy / Anodized / Silver 鋁/陽極/銀
CC312	M5 threaded bolt, 10.0x6.2mm head M5螺絲 · 頭部內徑6.2mm外徑10mm	Alloy / Anodized / Silver 鋁/陽極/銀
CC314	M5 threaded bolt, 8.5x5.9mm head M5螺絲 · 頭部內徑5.9mm外徑8.5mm	Alloy / Anodized / Black 鋁/陽極/黑
CC316	0.6mm spring, Fits M5 threaded bolts 0.6mm彈簧 · 適用M5調整螺絲	Stainless steel 不銹鋼
CC611	M6 threaded Bolt, 10.0x5.8mm head, free-style rotors compatible M6調整螺絲 · 頭部內徑5.8mm外徑10mm · 適用於表演車旋轉器	Steel / Argon / Silver 鐵/鍍氬/銀色
CC611B	M6 threaded Bolt, 10.0x5.8mm head, free-style rotors compatible M6調整螺絲 · 頭部內徑5.8mm外徑10mm · 適用於表演車旋轉器	Steel / Anodized / Black 鐵/鍍三價鉻/黑色
CM019B-1	M5 index adjuster, Shimano® STI shifting cable boss compatible Taiwan Patent: 168957 M5定格調整螺絲 · 公路車下管止栓用 · 適用於Shimano® STI系統 台灣專利:168957	Rubberized Cap/ Steel Bolt/Silver 皮革漆/ 鐵螺絲/銀色
CM019W	M5 index adjuster, Shimano® STI shifting cable boss compatible Taiwan Patent: 168957 M5定格調整螺絲 · 公路車下管止栓用 · 適用於Shimano® STI系統 台灣專利:168957	Rubberized Cap/ Steel Bolt/Silver 皮革漆/ 鐵螺絲/銀色

Part No.	Description	Material / Finish
CM136B	M5 index adjuster, Shimano® STI shifting cable boss compatible Taiwan Patent: 168957 M5定格調整螺絲 · 公路車下管止栓用 · 適用於Shimano® STI系統 台灣專利:168957	Rubberized Cap/ Alloy Bolt/Silver 皮革漆/ 鋁螺絲/銀色
CM136W	M5 index adjuster, Shimano® STI shifting cable boss compatible Taiwan Patent: 168957 M5定格調整螺絲 · 公路車下管止栓用 · 適用於Shimano® STI系統 台灣專利:168957	Rubberized Cap/ Alloy Bolt/Silver 皮革漆/ 鋁螺絲/銀色
CM081	M5 adjuster M5調整螺絲	Alloy / Anodized / Black 鋁/陽極/黑色
CM093J	Mini in-line adjuster Fits 4mm shift housing 迷你同軸式調整螺絲 適用於4mm變速外殼	Alloy / Anodized / Titanium finish 鋁/陽極/鈦色
CM160BJ	Mini in-line adjuster Fits 4mm shift housing 迷你同軸式調整螺絲 適用於4mm變速外殼	Alloy / Rubberized coating 鋁/皮革漆
CM160WJ	Mini in-line adjuster Fits 4mm shift housing 迷你同軸式調整螺絲 適用於4mm變速外殼	Alloy / Rubberized coating 鋁/皮革漆
CM157BJ	Rocket adjuster, For Shimano® STI Shift Levers. Adds index adjustments at the lever. "火箭"調整螺絲 · 適用於Shimano STI公路車手把	Alloy bolt / Argon plated / Black Rubberized cap / Black 鋁螺絲/鍍氬/黑 皮革漆/黑
CM131	Downtube braze-on mount road adjuster 調整螺絲座 · 適用於登山車、公路車系統	Stainless steel / Satin silver adjuster Plastic cap / Black 不銹鋼/不銹鋼銀/塑膠蓋/黑
CM167	Cycle-cross adjuster 調整螺絲組(Cycle-cross)	Alloy/Rubberized coating/ White 鋁/皮革漆/白色



Part No.	Description	Material / Finish
----------	-------------	-------------------



CM171BJ
Black/黑色



CM171DJ
Titanium/鈦色

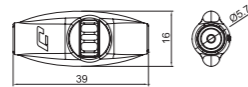

J2 In-line Index/
Detent Adjusters
定格式調整螺絲

Alloy/Anodized
鋁/陽極

Rubberized coating



CM171B1J
Black/黑色



CM171W1J
White/白色

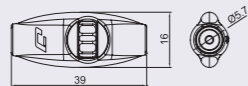

J2 In-line Index/
Detent Adjusters
定格式調整螺絲

Alloy/Rubberized
鋁/皮革漆



CM197B
Black/黑色



CM197W
White/白色



CM197S
Silver/銀色

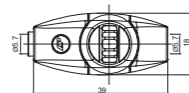

J2 In-line Index/
Detent Adjusters
定格式調整螺絲

Plastic
塑膠

Part No.	Description	Material / Finish
----------	-------------	-------------------



CM233-1DJ
Titanium/鈦色



CM233-1BJ
Black/黑色



CM233-1SJ
Silver/銀色

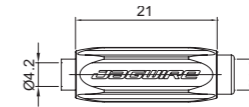

New- In-line Index/ Detent Adjusters
Fits 4mm shift housing
定格式調整螺絲
適用於4mm變速外殼

Alloy/Anodized
鋁/陽極

Rubberized coating

CM233-1WJ

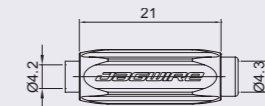

New- In-line Index/ Detent Adjusters
Fits 4mm shift housing
定格式調整螺絲
適用於4mm變速外殼

Alloy/Rubberized/White
鋁/皮革漆/白色

CM272BJ

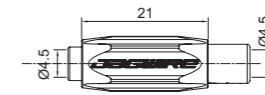

New- In-line Index/ Detent Adjusters
Fits 4.5mm shift housing
定格式調整螺絲
適用於4.5mm變速外殼

Alloy/Anodized/Black
鋁/陽極/黑色

CM265BJ

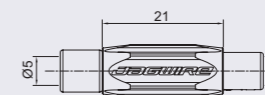

New-In-line index Adjusters
Fits 5mm Brake housing
定格式調整螺絲
適用於5mm煞車外殼

Alloy/Anodized/Black
鋁/陽極/黑色

SPECIFICATION 規格表

Standard 標準



Specification Chart- End Cap 端套產品規格表

Brake/Shift 煞車/變速	種類	Description 描述	Material/ Finish 材料	Part No. 型號	Color 顏色	Page 頁次
Brake	Open End Cap	Fit 5mm Housing	Alloy/Anodized	CC715#	B/G/R/S/U/E/N/C	P21
	Open End Cap(CNC)		Brass/Nickel plated	CC115-3/CC115-3E	S/B	P21
	Open End Cap(Non-Crimping)		Brass/Nickel plated	CC115-2D/CC115-2DE	S/B	P21
	Open End Cap		Brass/Nickel plated	CC115-2/CC115-2E	S/B	P21
	Open End Cap		Plastic	CC193	B	P21
	Lined End Cap		Alloy/Anodized	CM173#	B/G/R/S/U/E/N	P23
	Lined End Cap(For KEB)		Alloy/Anodized	CM029BJ	B	P23
	Nose End Cap		Alloy/Anodized	CM199#	B/G/R/S/U/E/N	P24
	Hooded End Cap		Alloy/ Anodized	CM269OJ	G	P26
	Anti-kink End Cap		Plastic	CC978	B	P26
Shift	Open End Cap	Fit 4mm Housing	Alloy/Anodized	CC464#	B/G/R/S/U/E/N/C	P20
	Open End Cap		Brass/Zinc plated	CC115-4I	B	P20
	Open End Cap		Plastic	CC115-4F/CC115-4FS	B/S	P20
	Sealed End Cap		Alloy/Anodized	CM176#	B/G/R/S/U/E/N	P22
	Sealed End Cap		Plastic	CM007/CM007S	B/S	P22
	Lined End Cap		Alloy/Anodized	CM251#	B/G/R/S/U/E/N	P23
	Nose End Cap		Plastic	CC115-4A/C/G/J	B	P24
	Dirt Guard		Alloy/Anodized	CM261#	B/G/R/S/U/E/N	P25
	Dirt Guard		Plastic	CM276	B	P25
	Hooded End Cap		Alloy/ Anodized	CM260OJ	G	P26
	Anti-kink End Cap	Plastic	CC976	B	P26	
	Open End Cap	Fit 4.5mm Housing	Brass/Nickel plated	CM115-4L/CM115-4N	B/S	P20
	Sealed End Cap		Alloy/Anodized	CM174#	B/G/R/S/U/E/N	P22
	Dirt Guard		Alloy/Anodized	CM262#	B/G/R/S/U/E/N	P25
	Hooded End Cap		Alloy/ Anodized	CM271OJ	G	P26
	Anti-kink End Cap		Plastic	CC977	B	P26

B:Black/G:Gold/R:Red/S:Silver/U:Blue/E:Cash Green/N:Tango/C:CP
 B:黑色/G:金色/R:紅色/S:銀色/U:藍色/E:美金綠/N:橘/C:本色



Hydraulic Brake Hose 碟煞高壓油管

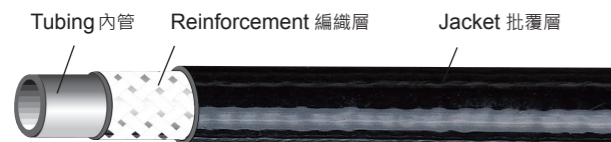

Item 項目	Dimension 尺寸	Tubing 內管	Reinforcement 編織層	Jacket 批覆層	Burst Strength 爆破係數	Compression 壓縮比		Color options 適用顏色
						at 1500psi	at 3000psi	
BE002	2.0 x 5.0	PBT	Polyester	Nylon	10000 psi+	1.7ml	3.9ml	Sole Colors 單色系列
FK008	2.0 x 5.0	Teflon	Kevlar	Nylon	12000 psi+	1.6ml	3.7ml	Sole & Braided Color 單色及編織系列

NOTE:

The hose materials and dimensions are available to specify according to requirements from customers.

Featuring Jagwire Teflon® tubing is optional for high and low temperature resistance.

注意:

高壓油管系列在原料與尺寸可依客戶特殊需求製作。

Jagwire 高壓油管特色在於可以承受高溫與低溫的使用條件

Available system: Shimano®, AVID®, Magura®, Formula®, Hayes®, Hope®, Tektro®

適用系統: Shimano®, AVID®, Magura®, Formula®, Hayes®, Hope®, Tektro®

Color Options 可供選擇顏色

※ PE001 Uses for Sole color only. PE001 只能使用在單色油管無法使用於編織系列

▲ Sole Colors 單色系列

	# 01 白 White		# 07 黑 Black		# Q1 艷陽橘 Orange
	# 24 熱情粉紅 Hot Pink		# 54 有機綠 Organic Green		# 56 高貴紅 Red
	# E6 西帝藍 SID Blue				

▲ Braided Series 編織系列

	# N3 細編織鈦 Light Braided Titanium		# N1 編織銀 Braided silver		# N2 編織金 Braided gold
	# B8 碳纖黑 Carbon Black		# N5 玫瑰金 Rose Thorn		# 95 編織棕 Braided carbon

Hydraulic Hose fittings 油管接頭零件

Part Number	Contain	Manufacturer	Compatible Models
S01		Shimano®	● XTR M975 ● Deore XT M775 ● Hone M535 ● SLX M665 ● Deore LX M585 ● Deore M525 ● Alfine S500
S02		Shimano®	● XTR M985 ● M988 ● XT M785 ● SLX M666 ● Deore M596
new S03		Shimano®	● Saint M810
M01		Magura®	● Clara 2000-2002 ● Gustav M 2000-2011 ● Julie HP 2009 ● Marta 2002-2010 ● Marta SL 2003-2011 ● Marta Gold 2007 ● Louise 2000-2010 ● Louise FR 2002-2006 ● Louise BAT 2008-2010 ● Louise Carbon 2008-2010
M02		Magura®	● MT2
M03		Magura®	● MT4, MT6, MT8
new M04		Magura®	● Gustav M 2000—2010 ● Marta 2007—2010 ● Marta Gold 2007 ● Marta SL 2008—2010
A01		AVID®	● XX World Cup 2010-2011 ● XX™ 2010-2011 ● Avid Juicy Ultimate™ ● Juicy Carbon ● Juicy Seven™
A02		AVID®	● Elixir CR ● Elixir CR MAGNESIUM ● Elixir R ● Elixir9 ● Elixir7 ● Elixir5 ● X0, X7, X9 ● XX2012+ ● World Cup 2012
A03		AVID®	● Elixir1 ● Elixir3 ● CODE 5 ● CODE 7 ● CODE(2008-2010) ● CODE / CODE R (2011)
F01		Formula®	● ORO
F02		Formula®	● R1R, R1, R0, RX, T1, Mega
H01		Hayes®	● Prime Expert ● Prime Pro ● Stroker Trail ● Stroker Carbon ● Stroker Ace ● Stroker Gram
new H02		Hayes®	● Stroker Ryde
T01		Tektro®	● Auriga Comp ● Auriga Comp WS ● Draco ● Draco WS ● Draco 2
new T02		Tektro®	● Orion, ● Auriga Pro

Shimano®

Part No.	Description	Material / Finish
CCC010	Compression Bushing Fits Shimano® System 迫緊環 適用Shimano®系統	Brass 銅/本色
CCZ018	Needle (Inserts) Fits Shimano® System 油針 適用Shimano®系統	Brass 銅/本色
CC944	Needle (Inserts) Fits Shimano® 2011XTR System 油針 適用Shimano® 2011XTR系統	Stainless Steel 不鏽鋼/本色
CCA058IA	Compression Nut (External) Fits Shimano® System 迫緊螺絲 (外牙式) 適用Shimano®系統	Steel / Black 鐵/黑色
CCA071I10	Compression nut (External) Fits Shimano® 2011XTR System 迫緊螺絲(外牙式) 適用Shimano® 2011XTR系統	Steel/ Anodized/Black 鐵/三價鉻鍍黑鋅/黑色
CC706	Banjo end Fits Shimano® System 胡琴接頭 適用Shimano®系統	Stainless Steel/Silver 不銹鋼/本色
CCF051T9	Compression nut Fits Shimano® 2011XTR System 壓著端端套 適用Shimano® 2011XTR系統	Stainless Steel/Silver 不銹鋼/本色
CCI010NR	O-Ring Fits Shimano® 2011XTR System O型環油封 適用Shimano® 2011XTR系統	NBR/Red 橡膠/紅色

AVID®

Part No.	Description	Material / Finish
CC708	Compression Bushing Fits Avid® System Juicy Series, CODE Series, Elixir Series, XX 迫緊環 適用Avid®系統 Juicy, CODE, Elixir, XX系列	Alloy/without finish 鋁/本色
CC704	Needle (Inserts) Fits Avid® System Juicy Series, CODE Series, Elixir Series, XX 油針 適用Avid®系統 Juicy, CODE, Elixir, XX系列	Steel / Black 鐵/黑色
CCA072I6	Compression Nut (External) Fits Avid® System Juicy Series, CODE Series, Elixir Series, XX 迫緊螺絲 (外牙式) 適用Avid®系統 Juicy, CODE, Elixir, XX系列	Steel/Black 鐵/黑色
CC740	Needle Bolt Fits Avid® System, Elixir Series 卡鉗端接頭 適用Avid®系統, Elixir系列	Stainless Steel/Silver 不銹鋼/本色
CC706	Banjo end Fits Avid® System Juicy5, 7, Carbon, ULTIMATE, XX 胡琴接頭 適用Avid®系統 Juicy5, 7, Carbon, ULTIMATE, XX系列	Stainless Steel/Silver 不銹鋼/本色
CCF051T9	Compression nut Fits Avid® System Juicy5, 7, Carbon, ULTIMATE, Elixir Series 壓著端端套 適用Avid®系統 Juicy5, 7, Carbon, ULTIMATE, Elixir系列	Stainless Steel/Silver 不銹鋼/本色
CCI010EB	O-Ring Fits Avid® System Juicy Series, XX, Elixir Series O型環油封 適用Avid®系統 Juicy, XX, Elixir系列	Polymer/Black 橡膠/黑色
CM185	Banjo bolt Fits Avid® System, Juicy5, 7, Carbon Series 卡鉗空心螺絲組合 適用Avid®系統 Juicy5, 7, Carbon系列	Steel/ Black 鐵/三價鉻鍍黑鋅/黑色

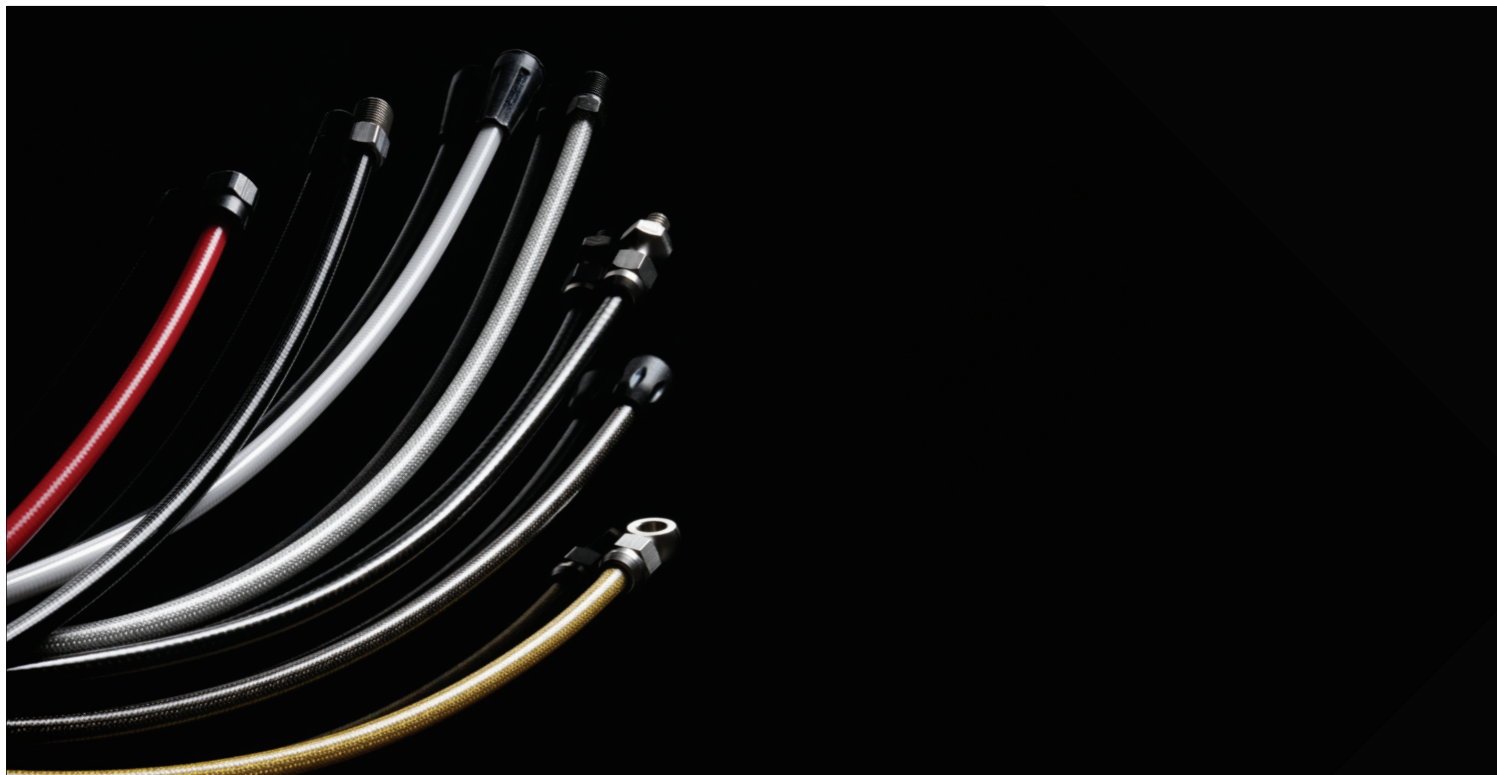

Formula®

Part No.	Description	Material / Finish
CC777	 Compression Bushing Fits Formula®-R1, THE ONE, MEGA System 迫緊環 適用Formula®-R1, THE ONE, MEGA系統	Brass 銅/本色
CC775	 Needle (Inserts) Fits Formula®-R1, THE ONE, MEGA System 油針 適用Formula®-R1, THE ONE, MEGA系統	Brass 銅/本色
CC776	 Compression Nut (External) Fits Formula®-R1, THE ONE, MEGA System 迫緊螺絲(外牙式) 適用Formula®-R1, THE ONE, MEGA系統	Steel/Silver 鐵/銀色
CC779	 Banjo End Fits Formula®-ORO System 胡琴接頭 適用Formula®-ORO系統	Stainless Steel/Silver 不銹鋼/本色
CC778	 Compression nut Fits Formula®-ORO System 胡琴接頭鎖螺絲 適用Formula®-ORO系統	Stainless Steel/Silver 不銹鋼/本色

Magura®

▲ Fits Magura System

Clara2000 to 2002, Gustav M 2000 to 2011, Julie HP 2009-2010, Marta 2002 to 2011, Marta SL 2003 to 2011, Marta Gold 2007, Louise 2000 to 2011, Louis FR 2002 to 2006, Louis BAT 2008 to 2011, Louis Carbon 2008 to 2011, Marta FR 2003-2010, MARTA SL MAGNESIUM, MT8, MT6, MT4, MT2

Part No.	Description	Material / Finish
CC707	 Compression Bushing Fits Magura® System 迫緊銅環 適用Magura®系統	Brass/without finish 銅/本色
CC703	 Needle (Insert) Fits Magura® System 油針 適用Magura®系統	Steel/ Anodized/Black 鐵/三價鉻鍍黑鋅/黑色
CCA10211	 Compression nut (External) Fits Magura® MT8, MT6, MT4 System 迫緊螺絲(外牙式) 適用Magura® MT8, MT6, MT4系統	Steel/ Without finish 鐵/本色
CCA071110	 Compression nut (External) Fits Magura® System 迫緊螺絲(外牙式) 適用Magura®系統	Brass/ Anodized/Black 銅/三價鉻鍍黑鋅/黑色
CC705	 Banjo End Fits Magura® System 卡鉗端接頭 適用Magura®系統	Steel/ Anodized/Black 鐵/三價鉻鍍黑鋅/黑色
CC630	 Compression Nut Fits Magura® System 壓著端套(孔內車牙紋) 適用Magura®系統	Alloy/without finish 鋁AL6061/本色

其它零配件

Part No.	Description	Material / Finish
CC396	 Disc Brake Shims 碟煞卡鉗專用墊片	Satinless Steel 不銹鋼/本色
CCG040-B	 Caliper-End Protector Fits Brake Lever End 保護套 適用於油壓碟刹把手端	Silicon / Black 橡膠/黑色
CCG005	 Cliper - End Protector Fits Brake Cliper End 保護套 適用於油壓碟刹卡鉗端	Silicon / Black 橡膠/黑色

Disc Brake Pads 來令片系列

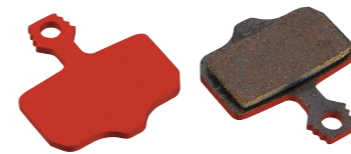
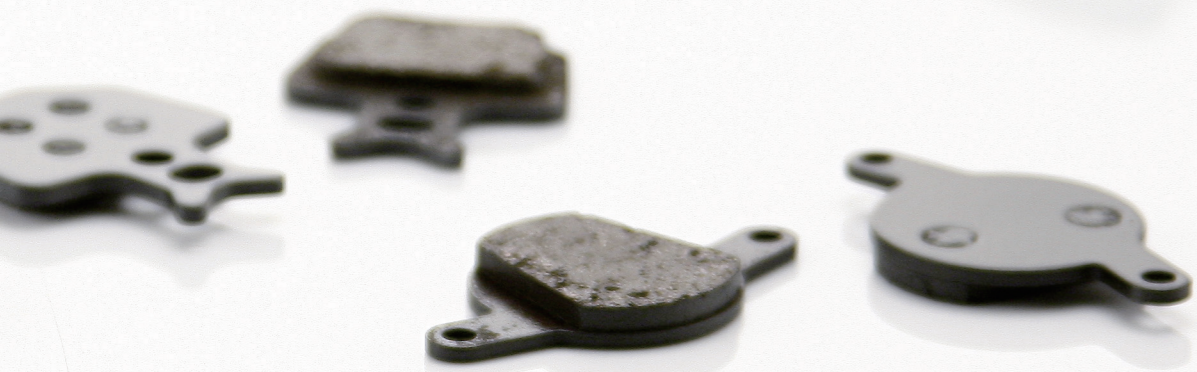

Comp 通用型

Jagwire Mountain disc brake pads are a great alternative to OEM. They feature a high performance, yet low-noise semimetallic compound mounted to a steel backing plate.

- 使用高質量鐵材質背版
- 複合式磨耗材質適用於一般氣候使用
- 低噪音、耐磨耗

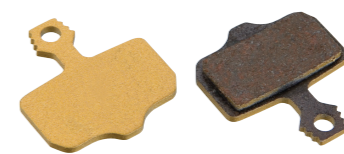

Lite 輕量型

pads feature a lightweight aluminum backing plate attached to the same quiet and high-performance semi-metallic compound found on our Mountain Sport series disc pads. Weight is reduced by nearly 50%. These pads are perfect for cross-country applications.

- 輕量化鋁合金背版 · 重量較為標準款碟煞來令片輕50%
- 複合式磨耗材質適用於一般天候、路況使用
- 低噪音、耐磨耗



Heavy Duty 耐用型

Mountain Pro Extreme pads feature an aggressive sintered compound that provides maximum stopping power making it perfect for DH riding. The dense, sintered compound also resists water making it extremely effective in wet conditions.







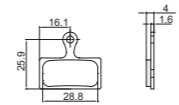

- 燒結來令片 · 長效能、耐磨耗的特性 · 給您更專業的煞停效果
- 專為濕式、泥濘路況或下坡賽道重量級車款設計使用

DISC BRAKE PADS

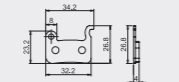

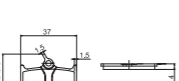

來令片

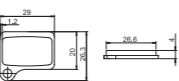
▲Disc Brake Pads are sold in pairs and where necessary replacement springs or clips are included.
▲Material: Semi-Metallic, Back Plate : Steel/Red



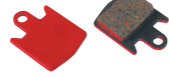
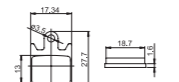

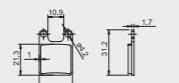
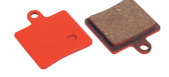
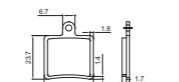
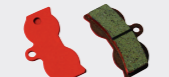

Shimano®

Brake Model	Comp 通用型	Lite 輕量型	Heavy Duty 耐用型
XTR M985, M988, M785, SLX M666, M675			DBL641-4 DBL641-1 DBL731-1 
XTR M965, M966, M975, M775, Saint M800, XT 765, Hone M601, SLX M665, LX 585, Deore M545, M535, R-505, S-500 M975, M775			DBL390-1 DBL490-1 DBL690-1 
M755DH			DBL320-1 DBL530-1 N/A
Deore M515, M515M, M515-LA, M525, M515-LA-M, M415, M465, M475, M485, M495, M395, CX75, C501, C601, M446, M447			DBL370-1 N/A N/A
Deore M555, M555M			DBL360-1 N/A N/A

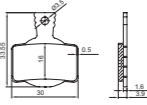

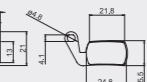

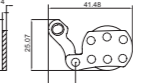
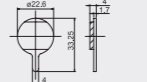
Hope®

Brake Model	Comp 通用型	Lite 輕量型	Heavy Duty 耐用型
M4			DBL290-1 N/A N/A
C2			DBL120-1 N/A N/A
Mini			DBL170-1 N/A N/A
XC			DBL130-1 N/A N/A



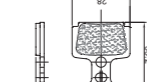



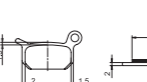

Magura®

Brake Model	Comp 通用型	Lite 輕量型	Heavy Duty 耐用型
MT8, MT6, MT4, MT2			DBL671-1 DBL671-3 N/A 
Marta 2002-2008, Marta SL			DBL380-1 N/A N/A
All Martas after 2009, All Louise 2007, Julie HP			DBL620-1 N/A N/A
Clara 2000, Louise 1999-2001			DBL310-1 N/A N/A
Julie 2001-2008			DBL350-1 N/A N/A
Clara 2001-2002, Louise FR, Louise 2002-2006			DBL340-1 N/A N/A

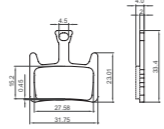

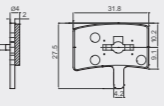
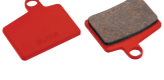
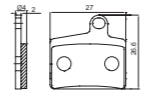

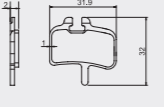
Formula®

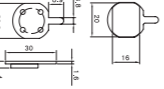
Brake Model	Comp 通用型	Lite 輕量型	Heavy Duty 耐用型
R1R, R1, RO, RX, T1, Mega			DBL581-2 DBL580-4 DBL711-1 
ORO			DBL400-1 DBL540-1 N/A
B4			DBL160-1 N/A N/A

Hayes®

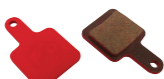
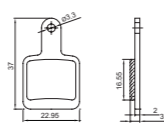
Brake Model	Comp 通用型	Lite 輕量型	Heavy Duty 耐用型
 Prime Expert, Prime Pro			DBL651-1 DBL651-3 N/A
Stroker Trial, Stroker Carbon, Stroker Gram			DBL600-1 N/A N/A
Stroker Ryde			DBL610-1 N/A N/A
HFX-Mag Series, HFX-9 Series, MX1			DBL300-1 N/A N/A
Sole, MX2, MX3			DBL430-1 N/A N/A

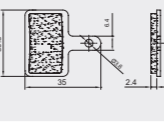
Tektro®

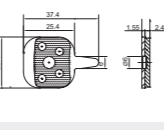
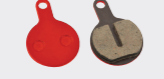
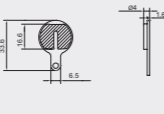
Brake Model	Comp 通用型	Lite 輕量型	Heavy Duty 耐用型
 Volans, Auriga Twin, Auriga SUB, Auriga E-SUB			DBL681-1 N/A N/A
Tektro® Auriga Pro, Auriga, Auriga E Comp, Aquila, Draco 2, Dorad, Draco Ws, Draco 2 Gemini, HD330			DBL370-1 N/A N/A
Tektro® IO			DBL560-1 N/A N/A
Tektro® Mechanical Disc Brake Lyra, IOX			DBL570-1 N/A N/A

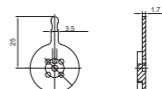

Promax®

Brake Model	Comp 通用型	Lite 輕量型	Heavy Duty 耐用型
Promax® Disc Brakes			DBL460-1 N/A N/A

RST®

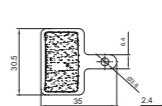
Brake Model	Comp 通用型	Lite 輕量型	Heavy Duty 耐用型
D-Power			DBL370-1 N/A N/A



Brake Pads

煞車皮

Brake Pad Compounds



- All-around performance
- Long wear

AW: 絕佳耐用效能 · 優異煞車效能適用於全路況



- Designed for wet weather control

Wet: 專為濕地路況設計增加製動力



- Specifically designed for carbon fiber braking surfaces

Carbon: 適用於Carbon輪圈

BRAKE PADS



適用於C夾公路車(Campagnolo)專用

Part No.	Description	Material / Color
P515AAB	Elite Road Skeleton Series 整組公路車系列	AW/Black /Alloy/ Silver / Length:54mm AW/黑色/鋁/銀色/54mm
P517AAB	Elite Road Skeleton Series 整組公路車系列	AW/Black /Alloy/ Black / Length:54mm AW/黑色/鋁/黑色/54mm
P459A	Elite Road 基本公路車系列	AW/Black /Alloy/ Silver Length:54mm AW/黑色/鋁/銀色/54mm
P475AAB	Elite Road 基本公路車系列	AW/Black /Alloy/ Black Length:54mm AW/黑色/鋁/黑色/54mm
P459RAB	Elite Road inserts 公路車更換式煞車皮	AW/Black/ Length:54mm AW/黑色/54mm
P459RXR	Elite Road Red Zone inserts 公路車更換式煞車皮(濕式)	RZ/Red Length:54mm RZ/紅色/54mm
P459RNU	Elite Road carbon inserts 公路車更換式煞車皮(Carbon)	Carbon/Blue/Length:54mm Carbon/藍色/54mm

煞車皮

適用於C夾公路車(Shimano 或 SRAM)專用

Part No.	Description	Material / Color
P509ABB	Sleek Comp, Road Force series 整組公路車C夾用(SRAM Force 適用)	AW/Black/Alloy/PVD Length:50mm AW/黑色/鋁/PVD鈦色/50mm
P491AAW	Sleek Comp, Road Force series 輕量化整組公路車C夾用(SRAM Force 適用)	AW/Silver/Alloy/PVD Length:50mm AW/銀色/鋁/PVD鈦色/50mm
P495AAW	Sleek Comp, Road Force series 輕量化整組公路車C夾用(SRAM Force 適用)	AW/Black/Alloy/PVD Length:50mm AW/黑色/鋁/PVD鈦色/50mm
P453R	Elite Road inserts 公路車更換式煞車皮	AW/Black Length:50mm AW/黑色/50mm
P453RXR	Elite Road Red Zone inserts 公路車更換式煞車皮(濕式)	RZ/Red Length:50mm RZ/紅色/50mm
P453RNU	Elite Road Carbon inserts 公路車更換式煞車皮(Carbon)	Carbon/Blue Length:50mm Carbon/藍色/50mm

適用於公路車基本款系列



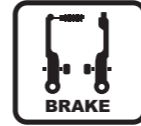

Part No.	Description	Material / Color
P451A	Basics comp road brake 公路車基本款	AW/Black/Length:50mm AW/黑色/50mm

BRAKE PADS

煞車皮

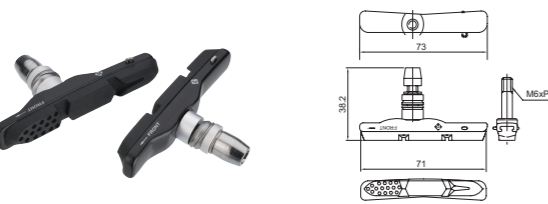
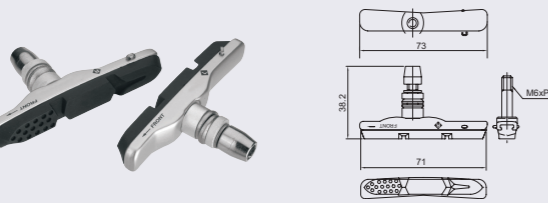

適用於V夾登山車專用

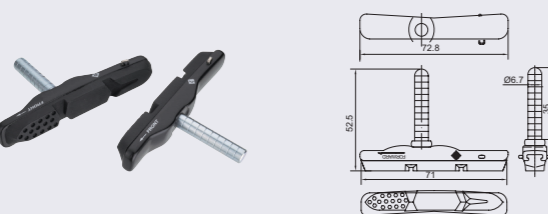
Part No.	Description	Material / Color
P935RAB	 <p>Brake Pad inserts 登山車更換式煞車皮</p>	AW/Black/Length:70mm AW/黑色/70mm
P935RXR	 <p>Brake Pad inserts 登山車更換式煞車皮</p>	RZ/Red/Length:70mm RZ/紅色/70mm
P91AC	 <p>V Brake Compatible 整組登山車系列 (V型夾器專用)</p>	AW/Black /Alloy/ Black Length:70mm AW/黑色/鋁/黑色/70mm
P91BC	 <p>V Brake Compatible 整組登山車系列 (V型夾器專用)</p>	AW/Black /Alloy/ Silver Length:70mm AW/黑色/鋁/銀色/70mm
P908C	 <p>V Brake Compatible 整組登山車系列 (V型夾器專用)</p>	AW/Black /Alloy/ Silver Length:70mm AW/黑色/鋁/銀色/70mm
P919V	 <p>Canti Brake Compatible 整組登山車系列 (懸吊式夾器專用)</p>	AW/Black /Alloy/ Black Length:70mm AW/黑色/鋁/黑色/70mm

Part No.	Description	Material / Color
P909V	 <p>Canti Brake Compatible 整組登山車系列 (懸吊式夾器專用)</p>	AW/Black /Alloy/ Silver Length:70mm AW/黑色/鋁/銀色/70mm
P91DR	 <p>Brake Pad inserts 登山車更換式煞車皮</p>	AW/Black Length:70mm AW/黑色/70mm
P91DRZ	 <p>Brake Pad inserts 登山車更換式煞車皮</p>	RZ/Red Length:70mm RZ/紅色/70mm
P90XR	 <p>Brake Pad inserts 登山車更換式煞車皮</p>	BS/Black Length:70mm BS/黑色/70mm
P90XRXR	 <p>Brake Pad inserts 登山車更換式煞車皮</p>	RZ/Red Length:70mm RZ/紅色/70mm

適用於登山車懸臂V夾基本款系列

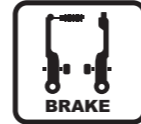

Part No.	Description	Material / Color
P909T	Compatible V Brake 整組登山車系列 (V型夾器專用)	AW/Black Length:70mm AW/黑色/70mm
P908T	Compatible V Brake 整組登山車系列 (V型夾器專用)	AW/Black Length:70mm AW/黑色/70mm
P908T-Y	Compatible V Brake 整組登山車系列 (V型夾器專用)	AW/Black/Yellow Length:70mm AW/黑色/黃色/70mm
P908T-R	Compatible V Brake 整組登山車系列 (V型夾器專用)	AW/Black/Red Length:70mm AW/黑色/紅色/70mm
P908T-P	Compatible V Brake 整組登山車系列 (V型夾器專用)	AW/Black/Pink Length:70mm AW/黑色/粉紅色/70mm
P908T-B	Compatible V Brake 整組登山車系列 (V型夾器專用)	AW/Black/Blue Length:70mm AW/黑色/藍色/70mm

Part No.	Description	Material / Color
P908T-G	Compatible V Brake 整組登山車系列 (V型夾器專用)	AW/Black/Gray Length:70mm AW/黑色/灰色/70mm
P947T	Compatible V Brake 整組登山車系列 (V型夾器專用)	AW/Black/Yellow Length:70mm AW/黑色/黃色/70mm
P908H	Compatible Canti Brake 整組登山車系列 (懸吊式夾器專用)	AW/Black Length:70mm AW/黑色/70mm
P909H	Compatible Canti Brake 整組登山車系列 (懸吊式夾器專用)	AW/Black Length:70mm AW/黑色/70mm
P910H	Compatible Canti Brake 整組登山車系列 (懸吊式夾器專用)	AW/Black Length:55mm AW/黑色/55mm
P900H	Compatible Canti Brake 整組登山車系列 (懸吊式夾器專用)	AW/Black Length:70mm AW/黑色/70mm

Global Offices

Jagwire USA

(Aftermarket Sales & Marketing)
6400 West 105th Street
Bloomington, MN 55438
Ph: +1 952 941 9391
Fx: +1 952 941 9799
Em: info@Jagwireusa.com



Jagwire Europe

(Aftermarket Sales & Marketing)
Avenue Edison 5 Zoning Nord
1300 Wavre, Belgium
Ph: +32 10 23 01 80
Fx: +32 10 23 01 81
Em: jageurope@nowcompany.com



Chia Cherne Europe

Industriepark Klein Frankrijk 50
9600 Ronse, Belgium
Ph: +32 (0)55 30 41 65
Fx: +32 (0)55 30 42 65
Em: info@Jagwire-europe.com



Chia Cherne China - Tian Jin

(OEM Sales & Manufacturing)
5 Xing-Fa Rd. Wan-Xing Gong Mao Yuan,
Chen Zui Town, Wu Qing Dist. Tian Jin.
Ph: +86 22 2214 0266
Fx: +86 22 2214 0277
Em: tj_jagwire@163.com



Chia Cherne China-Shenzhen

(OEM Sales & Manufacturing)
Haosan Shangxing
Industrial Zone No. 71
Nanhuan Road, Shajing Town
Boan Zone, Shen Zhen City
P.C.518125, China
Ph: +86 755 2727 2835
Fx: +86 755 2727 2837
Em: cougar@jagwire.com.tw



Chia Cherne Vietnam

(OEM Sales & Manufacturing)
Khu Công Nghiệp Bình Xuyên,
Huyện Bình Xuyên, Tỉnh Vĩnh Phúc,
Việt Nam
Ph: +84(211) 2222556~8
Fx: +84(211) 2222555
Em: jayme@jagwire.com.tw



Chia Cherne China - Kunshan

1465 Honghu Rd,
Kunshan Economic & Technical
Development Zone,
Jiangsu Province, China
Ph: +86 512 5016 5059
Fx: +86 512 5016 5060
Em: jcac@jagwire.com.tw



Head Office

Chia Cherne Taiwan

(OEM/Aftermarket Sales & Manufacturing)
No. 55, Alley 121, Lane 175,
Kousheng Rd. Changhua City, Taiwan
Ph: +886.4.732.3090
Fx: +886.4.732.1824
Em: taiwan@jagwireusa.com

MANUFACTURING PROCESS 製造流程

Cable Housing 外殼

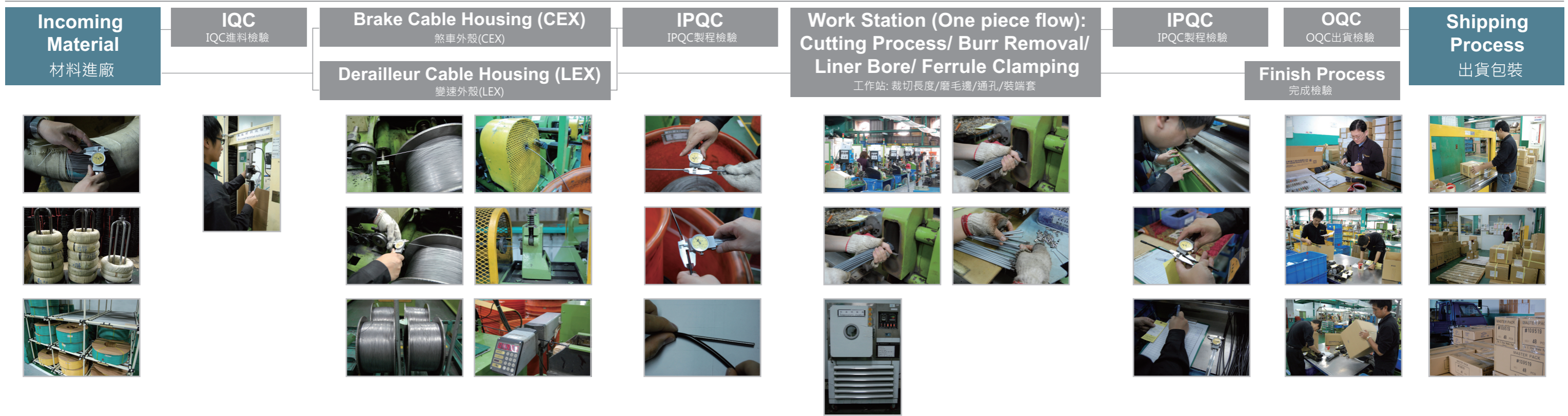

Brake Pads 煞車皮

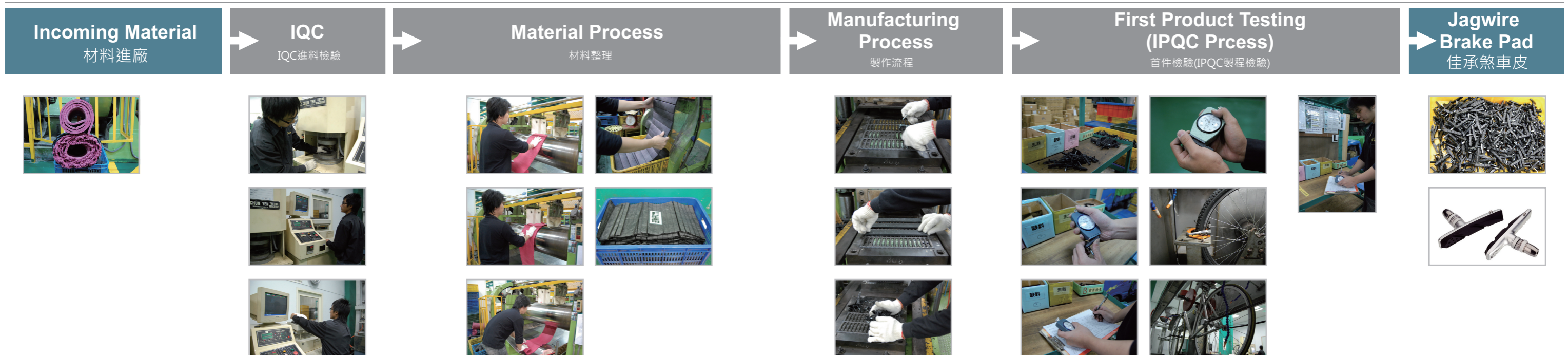

HEAD OFFICE CHIA CHERNE TAIWAN

📍 No. 55, Alley 121
Lane 175, Kousheng Rd.
Changhua City, Taiwan
☎ +886.4.732.3090
☎ +886.4.732.1824
✉ taiwan@jagwireusa.com

CHIA CHERNE EUROPE

📍 Industriepark Klein Frankrijk 50
9600 Ronse, Belgium
☎ +32 (0)55 30 41 65
☎ +32 (0)55 30 42 65
✉ info@Jagwire-europe.com

CHIA CHERNE CHINA - KUNSHAN

📍 1465 Honghu Rd,
Kunshan Economic & Technical Development Zone,
Jiangsu Province, China
☎ +86 512 5016 5059
☎ +86 512 5016 5060
✉ jcac@jagwire.com.tw

CHIA CHERNE CHINA - TIAN JIN

📍 NO.5 Xing-Fa Rd.Wan-Xing Gong Mao Yuan,
Chen Zui Town,Wu Qing Dist.Tian Jin City.
☎ +86 22 2214 0266
☎ +86 22 2214 0277
✉ tj_jagwire@163.com

CHIA CHERNE CHINA-SHENZHEN

📍 Haosan Shangxing
Industrial Zone No. 71
Nanhuan Road, Shajing Town
Boan Zone, Shen Zhen City
P.C.518125, China
☎ +86 755 2727 2835
☎ +86 755 2727 2837
✉ cougar@jagwire.com.tw

CHIA CHERNE VIETNAM-(KAKOSI CO.,LTD)

📍 Khu Công Nghiệp Bình Xuyên,
Huyện Bình Xuyên, Tỉnh Vĩnh Phúc,
Việt Nam
☎ +84(211) 2222567
☎ +84(211) 2222555
✉ jayme@jagwire.com.tw