



INDEX 目錄

02	Braking System	煞車系統
05	Shifting System	變速系統
07	Elite LINK System	極致節式外殼系統
09	Elite Sealed System	極致全防護系統
12	Housing Color	外殼顏色
16	Installation Guide	零件裝配圖
18	Housing Parts	外殼零件
26	Tube Tops	保護套
27	Frame Parts	車架零件
29	Cable Parts	內線零件
32	Braking Parts	煞車零件
34	Adjuster	調整螺絲



Brake cable and housing 煞車內線與外殼系統

Elite

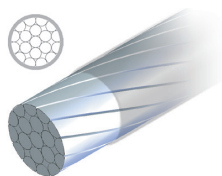

- ▲ Ultra-low friction cable with Speed Lube housing which provides rapid braking responsiveness and precise shifting.
超低摩擦係數·搭配JAGWIRE新全注油Speed Lube外殼·可提供快速回應煞車力/精準的變速。
- ▲ Stainless cable with pre-stretches and coated ultra-slick polymer to get the ultra low friction function.
經過研磨不鏽鋼內線搭配特殊批覆層以達到極致的低摩擦效能
- ▲ STS-LF(Ultra-low friction, Stainless)不鏽鋼低摩擦內線

Pro-TEC

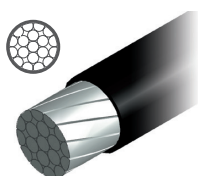

- ▲ Teflon coating: Friction-free, low-maintenance(easy clean)&eco-friendly for all-weather performance
鐵氟龍批覆:摩擦係數低、易保養(容易清潔)、環保特性可提供全天候使用。
- ▲ slick cable coated Teflon to get the low friction function.
預拉整直內線批覆鐵氟龍以達到低摩擦效能
- ▲ TEC-ST(Teflon coated, Stainless) 鐵氟龍不鏽鋼研磨內線
TEC(Teflon coated, Galvanized) 鐵氟龍鍍鋅研磨內線

Pro

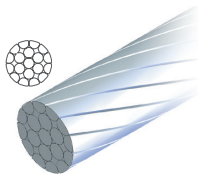

- ▲ Pre-stretching can more directly on the feedback off brake & precise shifting performance
內線已做預拉整直可讓煞車回饋更直接與更精準的變速
- ▲ Smooth surface & low friction
表面光滑&低摩擦力
- ▲ STS(Slick, Stainless)不鏽鋼研磨內線
GAS(Slick, Galvanized)鍍鋅研磨內線

Universal

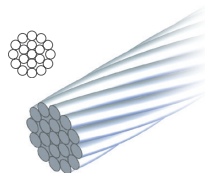

- ▲ Regular cable
標準內線系統
- ▲ STR(Stainless Steel)不鏽鋼內線
GAR(Galvanized Steel)鍍鋅內線

Brake Cable Nipple Options 煞車內線銜頭規格

Nipples are die-cast onto cable ends for durability and strength, adding to rider safety and confidence. All nipple types are compatible with any required cable specifications.

內線尾端的銜頭是由鋅水經過鑄造程序所完成的·耐久性與強度提供了更安全與更安心的騎乘條件。所有的銜頭樣式皆能夠符合目前所有煞車與變速系統的需求。



B02 (7*6)
Shimano® & SRAM®
MTB, BMX system compatible
適用於Shimano® & SRAM®
登山車, 表演車煞車系統

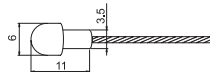

B04 (6*11)
Shimano® & SRAM®
Road System compatible
適用於Shimano® & SRAM®
公路車系統

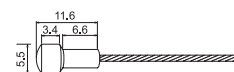

B05 (5.5*11.6)
Campagnolo®
Road brake system compatible
適用於Campagnolo®
公路車煞車系統



Elite

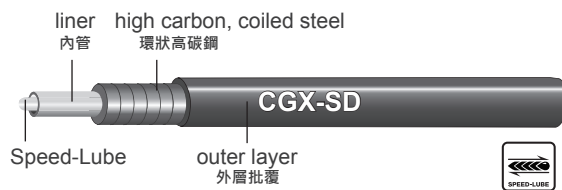

CGX-SD

- ▲ Low compression
低壓縮比
- ▲ Ultra low friction
超低摩擦係數
- ▲ With Speed Lube liner
搭配速動全注油內管

Pro

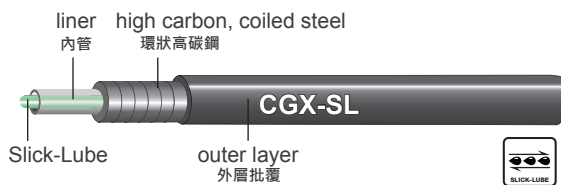

CGX-SL

- ▲ Low compression
低壓縮比
- ▲ Low friction
低摩擦係數
- ▲ With Slick Lube liner
搭配順滑全注油內管

Universal

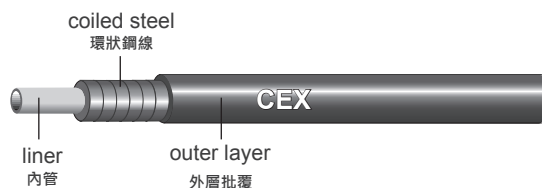

CEX

- ▲ Regular housing
標準外殼

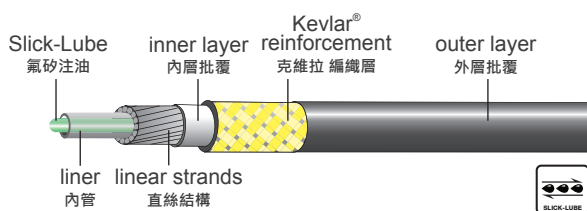

KEB™

- ▲ Kevlar® brand fiber reinforced with compressionless housing for super braking
Kevlar®(克維拉®)高性能纖維包裹直絲結構鋼線提供高性能煞車
- ▲ Ideal for cable-actuated disc brakes
機械式碟煞的最佳搭配首選
- ▲ Super light weight (30% less than standard coiled brake housing)
輕量化(較一般環狀外殼輕30%)
- ▲ Hi-tech look
高技術的外觀
- ▲ Compressionless
零壓縮比
- ▲ Slick-Lube specified
搭配順滑全注油內管

CAUTION: Reinforced (linear shell) brake housing must be used with Jagwire specific lined alloy ferrules or POP adapters to ensure compressionless braking performance

注意: 直絲結構強化外殼使用於煞車線必須搭配Jagwire特殊襯裡鋁端套系列或POP端套系列已確保更完整的煞車性能。POP端套為V刹夾器彎管專門設計的



Shift Housing 變速外殼

Elite

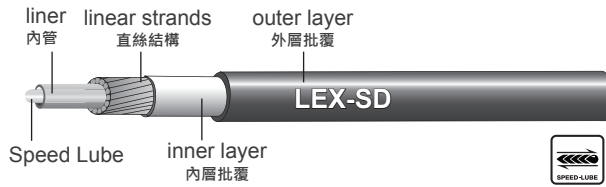

LEX-SD

- ▲ Compressionless
直絲結構·零壓縮比
- ▲ Double plastic layer
雙層批覆技術
- ▲ Ultra low friction
超低摩擦係數
- ▲ With Speed Lube liner
搭配速動全注油內管

Pro

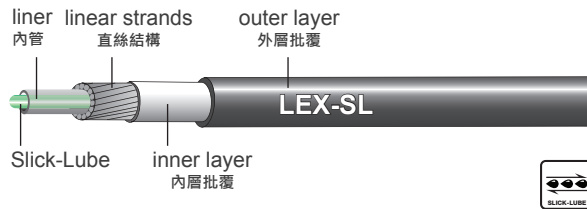

LEX-SL

- ▲ Compressionless
直絲結構·零壓縮比
- ▲ Double plastic layer
雙層批覆技術
- ▲ Low friction
低摩擦係數
- ▲ With Slick Lube liner
搭配順滑全注油內管

Universal

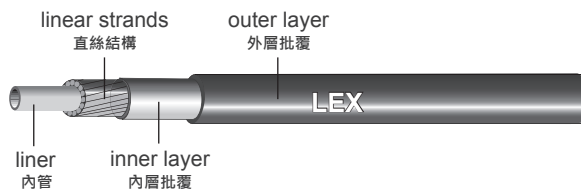

LEX

- ▲ Compressionless
直絲結構·零壓縮比
- ▲ Double plastic layer
雙層批覆技術
- ▲ Regular housing
標準外殼



Elite LINK System 極致節式外殼系統

Link Brake and Shift Systems 節式外殼系統

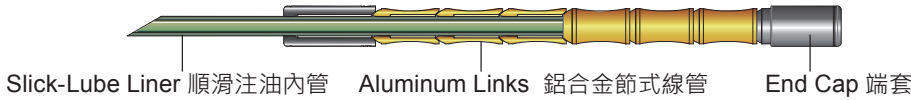

Compressionless, Aluminum link construction.

全新的超低壓縮比節式結構

Aluminum link construction delivers some major benefits. It's compressionless delivering precision shifting, but it also allows for tight bends without kinking during tricky cable runs. It's also 20% lighter than traditional shift housing and 50% lighter than tradition brake housing. Combine these benefits with our slick-lube liners that dramatically reduce friction and you've got the best of performance and style.

全新的鋁製節式外殼結構設計，提供了大幅度的重量減輕、超低壓縮比，以及對應大角度彎曲的使用需求。搭配全順滑注油內管(Slick Lube)技術，提供絕佳的性能及與眾不同的風格。

Reduced Weight 超輕量化

- ▲ 50% lighter than traditional brake housing
較傳統煞車外殼結構輕量約50%
- ▲ 20% lighter than traditional shift housing
較傳統變速外殼結構輕量約20%

Compressionless Performance 超低壓縮比

- ▲ Compressionless aluminum construction delivers precision shifting and smooth, powerful braking
超低壓縮比的設計結構，不僅提供了精準的變速效能，亦能強化敏銳的煞車手感

Durable, Flexible Construction 靈活彎曲且耐用的結構

- ▲ Perfect for tricky cable runs with tight bends
靈活對應大角度彎曲的使用需求

Unique, Attention Grabbing Appearance 吸引目光的獨特設計

- ▲ Anodized finish is extremely durable and attractive
兼具品味及質感的外型設計

Color options

可供選擇顏色





Elite Sealed System 極致全防護系統

Sealed Brake and Shift Systems 全防護系統

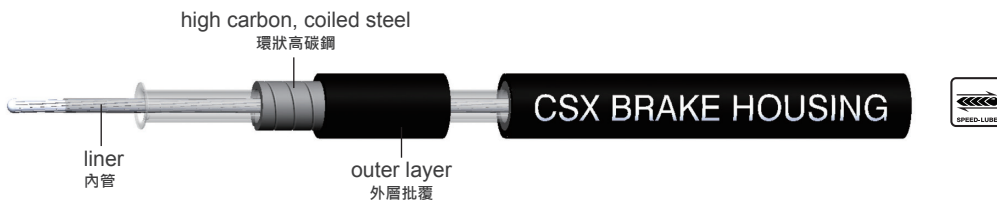

Jagwire sealed systems include liners that run continuously from the lever to the brake or derailleur. This protects the cable and housing from dirt, mud or anything else that can cause friction. But because the liner runs the full length of the cable, a specially developed cable coating and lube are used to keep friction to a minimum. Jagwire 變速與煞車全防護系統採用從頭到尾的內管設計,完全阻隔任何會影響摩擦力的汙泥與雜質。為了搭配全通內管,在外殼上開發特殊搭配低摩擦內線系統與新速動油品來達到極致低摩擦需求。

Completely sealed 長效/阻絕汙泥

- ▲ Continuous liner running from the lever to the brake caliper could offer completely sealed to prevent dirt and debris
全防護系統採用從手把端到卡鉗全內管防護,完全阻隔汙泥與雜質的影響

Reduce friction 降低摩擦力

- ▲ Polymer coated cable and paired it with the new Speed-Lube ultra slick lubricate used throughout the liner could reduce friction
搭配批覆內線與新速動全注由內管降低摩擦係數

Color options 可供選擇顏色





Housing Color 外殼顏色



BICYCLE CABLE HOUSING 外殼系列

Standard Series 標準系列

※All colors are available for Brake Housing (CEX, CGX-SL) and Shift Housing (LEX, LEX-SL) except #09.

各色均適用於煞車CEX,CGX-SL外殼系列與變速 LEX, LEX-SL外殼系列,除#09外

※#09 Translucent available with 5mm on coiled type housing only.

#09只提供5mm CEX環狀結構規格

※#01, #07, #56 are available for CGX-SD, LEX-SD

#01, #07, #56適用CGX-SD, LEX-SD



Frozen Series 平光系列

※All colors are available for Brake Housing (CGX-SL, CGX,SD) and Shift Housing (LEX-SL, LEX-SD)

各色均適用於煞車CGX-SL, CGX,SD外殼系列,與變速 LEX-SL, LEX-SD外殼系列



ID-line 指示線系列

※All colors are available for Brake Housing (CGX-SL) and Shift Housing (LEX-SL).

各色均適用於煞車CGX-SL外殼系列,與變速 LEX-SL外殼系列

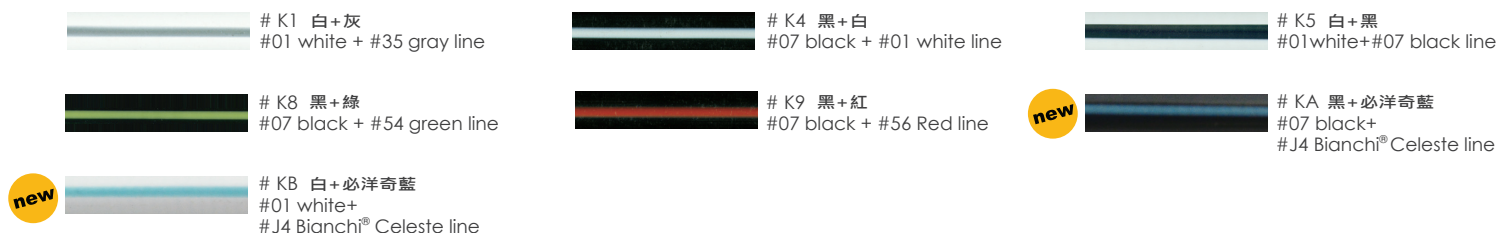

Reflective Housing 反光系列

※All colors are available for Brake Housing (CEX, CGX-SL).

各色均適用於煞車CEX, CGX-SL外殼系列.



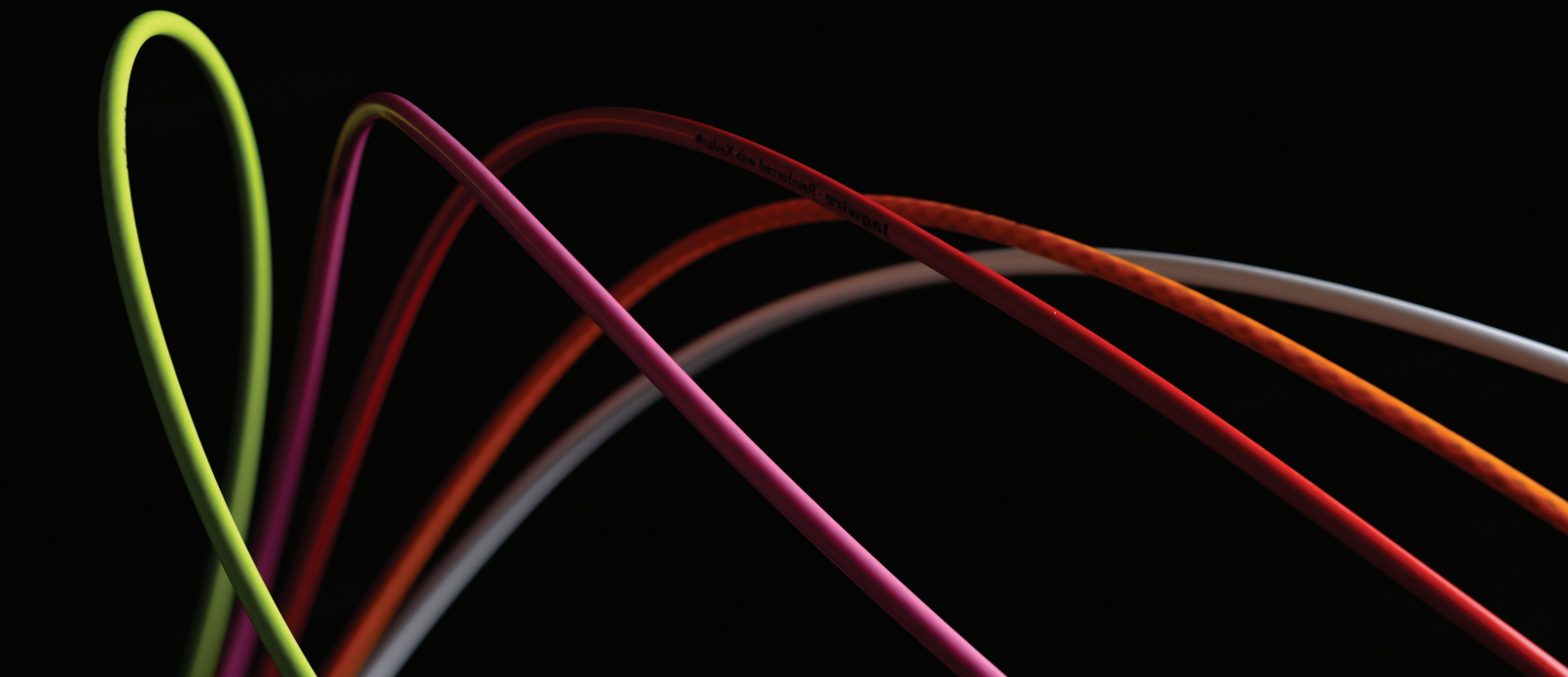

Braided Series 編織系列

※O.D. 5mm available for brake, O.D. 4.5mm available for shift.

煞車外殼外徑為5MM · 變速外殼外徑為4.5MM

※All colors are available for Brake Housing (CGX-SL) and Shift Housing (LEX-SL).

各色均適用於煞車CGX-SL外殼系列與變速 LEX-SL外殼系列









Color options 可供選擇顏色

 # 95 編織棕 Braided carbon	 # 99 編織鈦 Braided titanium	 # A3 編織黑 Braided black	 # A9 細編織棕 Light braided carbon
 # N1 編織銀 Braided silver	 # N2 編織金 Braided gold	 # N3 細編織鈦 Light Braided titanium	 # M1 編織白 Braided white
 # M2 編織天空藍 Braided Sky Blue	 # M3 編織紅 Braided Red	 # N9 編織淡藍 Braided light blue	 # B8 碳纖黑 Carbon Black
 # A5 細編織銀 Light Braided Silver	 # B1 細編織黑 Light Braided Black	 # 96 編織褐 Braided Bronze	

KEB Reinforced Series KEB強化編織系列

※ All color available for Brake Housing KEB-SL

各顏色均適用於煞車KEB-SL外殼系列

 # 21 馬吉斯橘 Maxxis® Orange	 # B8 碳纖黑 Carbon Black	 # E4 神秘紫 Purple	 # 54 有機綠 Organic Green
 # 56 火熱紅 Red	 # E6 西帝藍 SID Blue	 # Q1 艷陽橘 Orange	 # E9 銀河灰 Ice Gray
 # 86 鵝黃 Yellow			



Accessories

配件



INSTALLATION GUIDE 零配件裝置圖

Road Bicycle 公路車

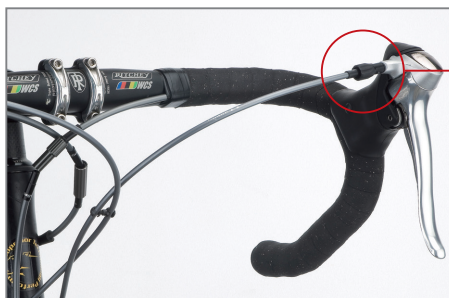

Rocket adjuster

火箭調整螺絲

CM157BJ



In-line Adjuster Barrel

同軸式調整螺絲

CM233-1DJ



CM093J



Cable Tips

線尾套系列



CM743-OJ



CC117-C



Tube Tops

保護套

CCG017-BJ, CCG025-BJ

CCG037

CCG043BJY

CCG052B

CCG052T

CCG052R





Cable Raincoat

防污泥端套組

CM2600J



CM261BJ



CM276



Rotating Hook

導管集線器

CM143



CM143W



Adjustable Cable Grip

止栓轉接座系列

CM017-2



CM017-B



Stick-on Guide

自黏式導線座系列

CME013B



CME011















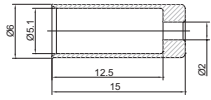

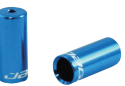
ACCESSORIES

Housing Parts

Open End Cap for Shift Housing 變速用標準端套

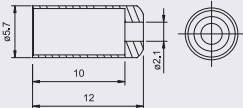
Part No.	Description	Material / Finish
 <p>CC464BJ Black/黑色</p> <p>CC464CJ CP/本色</p> <p>CC464OJ Gold/金色</p>	 <p>Open End Cap, Fits 4mm Shifting housing (Recommended Use: SRAM® & Shimano® Shiffig System)</p> <p>標準端套, 適用4mm變速外殼 (建議使用於SRAM® & Shimano®系統)</p>	<p>Alloy / Anodized</p> <p>鋁/陽極</p>
 <p>CC464RJ Red/紅色</p> <p>CC464SJ Silver/銀色</p> <p>CC464UJ Blue/藍色</p> <p>CC464EJ Cash Green/美金綠</p> <p>CC464NJ Tango/橘色</p> <p>new CC464AJ Apple Green/蘋果綠</p> <p>new CC464PJ Purple/紫色</p>		
 <p>CC115-4I Black/黑色</p>	 <p>Open End Cap (CNC), Fits 4mm thicker design for better enforcement</p> <p>標準端套(CNC車削), 適用4mm變速外殼· 前端加厚設計·強度增加</p>	<p>Brass / Zinc plated</p> <p>銅/鍍鋅</p>
 <p>CC115-4F Black/黑色</p> <p>CC115-4FS Silver/銀灰色</p>	 <p>Open End Cap, Fits 4mm housing</p> <p>標準端套, 適用4mm變速外殼</p>	<p>Plastic</p> <p>塑膠</p>
 <p>CM115-4N silver/銀色</p>	 <p>Open End Cap (CNC), Fits 4.5mm Housing</p> <p>標準端套(CNC), 適用4.5mm外殼</p>	<p>Brass / Nickel Plated Coating</p> <p>銅/鍍鎳</p>
 <p>CM115-4L Black/黑色</p>	 <p>Open End Cap (CNC) Fit 4.5mm Housing</p> <p>標準端套(CNC), 適用4.5mm外殼</p>	<p>Brass / Nickel Plated</p> <p>銅 / 鍍鎳</p>

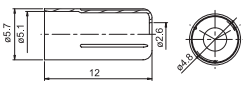
Open End Cap for Brake Housing 煞車用標準端套

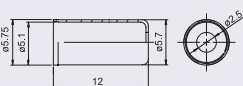





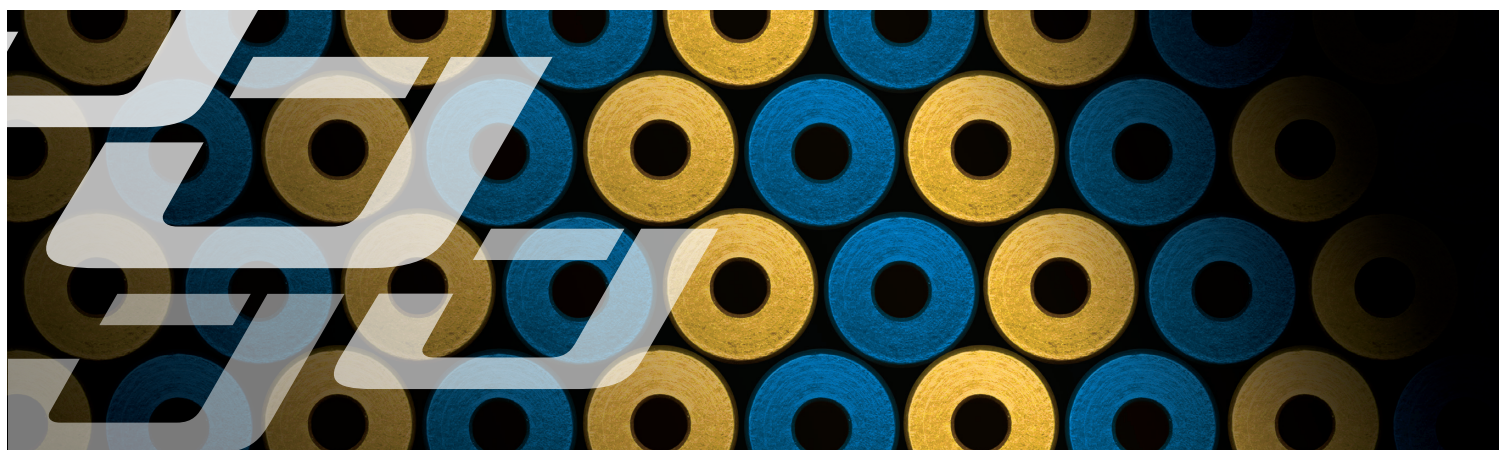



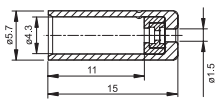





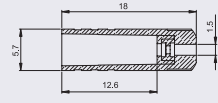

Part No.		Description	Material / Finish
 CC715BJ Black/黑色	 CC715CJ CP/本色	 CC715OJ Gold/金色	 <p>Open End Cap, Fits 5mm Brake housings</p> <p>標準端套, 適用5mm煞車外殼</p> <p>Alloy/Anodized 鋁/陽極</p>
 CC715RJ Red/紅色	 CC715SJ Silver/銀色	 CC715UJ Blue/藍色	
 CC715EJ Cash Green/美金綠	 CC715NJ Tango/橘色	 new CC715AJ Apple Green/蘋果綠	
 new CC715PJ Purple/紫色			
 CC115-3 Satin silver/銀色	 CC115-3E Black/黑色	 <p>Open End Cap (CNC), Fits 5mm CEX, CGX</p> <p>標準端套(CNC車削), 適用5mmCEX, CGX外殼· 前端加厚設計·強度增加</p> <p>Brass / Nickel plated 銅/鍍鎳</p>	
 CC115-2D Satin silver/銀色	 CC115-2DE Black/黑色	 <p>Non-Crimping End Cap, Fits 5mm CEX, CGX Taiwan Patent: 158536</p> <p>爪式端套, 適用5mmCEX·CGX外殼 台灣專利:158536</p> <p>Brass / Nickel plated 銅/鍍鎳</p>	
 CC115-2 Satin silver/銀色	 CC115-2E Black/黑色	 <p>Open End Cap, Fits 5mm CEX, CGX</p> <p>標準端套, 適用5mmCEX·CGX外殼</p> <p>Brass / Nickel plated 銅/鍍鎳</p>	

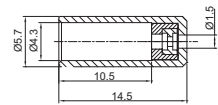
ACCESSORIES











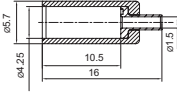





Housing Parts

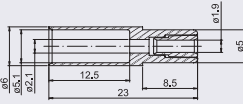

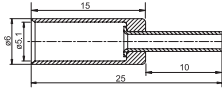





Sealed End Cap for Shift Housing 變速用油封端套

Part No.	Description	Material / Finish				
 <p>CM176BJ Black/黑色</p>	 <p>Sealed End Cap, Fits 4mm LEX housing 油封端套, 適用4mm LEX變速外殼</p>	Alloy / Anodized 鋁/陽極				
 <p>CM176OJ Gold/金色</p>	 <p>CM176RJ Red/紅色</p>	 <p>CM176SJ Silver/銀色</p>	 <p>CM176UJ Blue/藍色</p>	 <p>CM176EJ Cash Green/美金綠</p>	 <p>CM176NJ Tango/橘色</p>	
 <p>CM007 Black/黑色</p>	 <p>CM007S Silver/銀灰色</p>	 <p>Sealed End Cap, Fits 4mm LEX housing 油封端套, 適用4mm LEX變速外殼</p>	Plastic 塑膠			
 <p>CM207-A Black/黑色</p>	 <p>Sealed End Cap, Fits 4mm housing 油封端套, 適用於4mm外殼</p>	Brass / Zinc plated 銅/鍍鋅				
 <p>CM174BJ Black/黑色</p>	 <p>CM174OJ Gold/金色</p>	 <p>CM174RJ Red/紅色</p>	 <p>CM174SJ Silver/銀色</p>	 <p>CM174UJ Blue/藍色</p>	 <p>CM174EJ Cash Green/美金綠</p>	 <p>CM174NJ Tango/橘色</p>

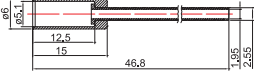
Lined End Caps 襯裡端套

Part No.	Description	Material / Finish
 CM251BJ Black/黑色	 <p>Short Nosed End Cap Fits 4mm housing</p> <p>短鼠尾端套, 4mm外殼使用</p>	Alloy / Anodized / POM 鋁/陽極/塑鋼
 CM251OJ Gold/金色		
 CM251RJ Red/紅色		
 CM251SJ Silver/銀色		
 CM251UJ Blue/藍色		
 CM251EJ Cash Green/美金綠		
 CM251NJ Tango/橘色		
 CM029BJ Black/黑色	 <p>Fits 5mm Housing, designed specially for KEB® brake housing to work with a standard guide pipes and adjusters with a smaller inner diameter.</p> <p>適用5mm外殼, 專為KEB外殼設計, 內縮設計剛好可放置於夾器內彎管</p>	Alloy / Anodized 鋁/陽極
 CM029SJ Sliver/銀色		
 CM173BJ Black/黑色	 <p>Lined End Cap, Fits 5mm Brake housings, built-out polymer nose, prevents abrasion of coated cables and reduces friction</p> <p>襯裡端套, 適用5mm剎車外殼, 防止刮傷內線批覆層並減少摩擦</p>	Alloy/Anodized 鋁/陽極
 CM173OJ Gold/金色		
 CM173RJ Red/紅色		
 CM173SJ Silver/銀色		
 CM173UJ Blue/藍色		
 CM173EJ Cash Green/美金綠		
 CM173NJ Tango/橘色		

Nose End Cap 鼠尾端套











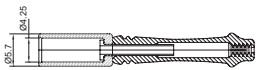



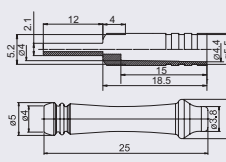

Part No.	Description	Material / Finish
 CM199BJ Black/黑色	 <p>Nosed End Cap, Fits 5mm Brake housing</p> <p>鼠尾端套, 適用5mm剎車外殼</p>	Alloy / Anodized 鋁/陽極
 CM199OJ Gold/金色		
 CM199RJ Red/紅色		
 CM199SJ Silver/銀色		
 CM199UJ Blue/藍色		
 CM199EJ Cash Green/美金綠		
 CM199NJ Tango/橘色		

ACCESSORIES

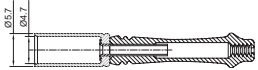







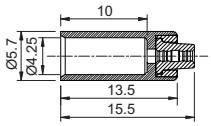

Housing Parts

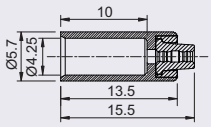

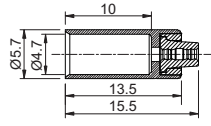
Dirt Guard 防汙泥端套組

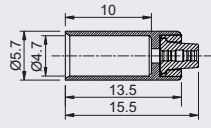

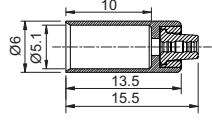

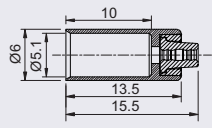
Part No.	Description	Material / Finish			
 CM261BJ Black/黑色	 Dirt Guard Kit, Fits 4mm Shifting housing, Prevent dust from entering the housing 防汙泥端套組, 適用4mm變速外殼, 防止髒汙進入外殼	Alloy /Anodized Silicon Gel /Black 鋁/陽極 矽膠/黑色			
 CM261OJ Gold/金色	 CM261RJ Red/紅色	 CM261SJ Silver/銀色	 CM261UJ Blue/藍色	 CM261EJ Cash Green/美金綠	 CM261NJ Tango/橘色
 new CM276 Black/黑色	 Dirt Guard Kits, Fits 4mm housing, Prevent dust from entering the housing 防汙泥端套組, 適用於4mm外殼,防止髒汙進入外殼	Plastic/ Silicon / Black 塑膠/矽膠/黑色			
 CM262BJ Black/黑色	 Dirt Guard Kit, Fits 4.5mm Shifting housing, Prevent dust from entering the housing 防汙泥端套組, 適用4.5mm變速外殼, 防止髒汙進入外殼	Alloy /Anodized Silicon Gel /Black 鋁/陽極 矽膠/黑色			
 CM262OJ Gold/金色	 CM262RJ Red/紅色	 CM262SJ Silver/銀色	 CM262UJ Blue/藍色	 CM262EJ Cash Green/美金綠	 CM262NJ Tango/橘色

Hooded End Cap 防汙泥端套(精實版)

Part No.	Description	Material / Finish
<p>CM260OJ Gold/金色</p>  	<p>Hooded End Cap Fits 4mm Shifting housing, An Extra layer of protection against dirt</p> <p>防汙泥端套(精實版) 適用於4mm外殼 增加結構防止髒汙進入</p>	<p>Alloy/ Anodized/Gold NBR / Black</p> <p>鋁/陽極/金色 橡膠/黑色</p>
<p>new CM260BJ Black/黑色</p>  	<p>Hooded End Cap Fits 4mm Shifting housing, An Extra layer of protection against dirt</p> <p>防汙泥端套(精實版) 適用於4mm外殼 增加結構防止髒汙進入</p>	<p>Alloy/Anodized/Black NBR/Black</p> <p>鋁/陽極/黑色 橡膠/黑色</p>
<p>CM271OJ Gold/金色</p>  	<p>Hooded End Cap Fits 4.5mm Shifting housing, An Extra layer of protection against dirt</p> <p>防汙泥端套(精實版) 適用於4.5mm外殼 增加結構防止髒汙進入</p>	<p>Alloy/ Anodized/Gold NBR / Black</p> <p>鋁/陽極/金色 橡膠/黑色</p>
<p>new CM271BJ Black/黑色</p>  	<p>Hooded End Cap Fits 4.5mm Shifting housing, An Extra layer of protection against dirt</p> <p>防汙泥端套(精實版) 適用於4.5mm外殼 增加結構防止髒汙進入</p>	<p>Alloy/Anodized/Black NBR/Black</p> <p>鋁/陽極/黑色 橡膠/黑色</p>
<p>CM269OJ Gold/金色</p>  	<p>Hooded End Cap Fits 5.0mm brake housing, An Extra layer of protection against dirt</p> <p>防汙泥端套(精實版) 適用於5mm外殼 增加結構防止髒汙進入</p>	<p>Alloy/ Anodized/Gold NBR / Black</p> <p>鋁/陽極/金色 橡膠/黑色</p>
<p>new CM269BJ Black/黑色</p>  	<p>Hooded End Cap Fits 5.0mm brake housing, An Extra layer of protection against dirt</p> <p>防汙泥端套(精實版) 適用於5mm外殼 增加結構防止髒汙進入</p>	<p>Alloy/ Anodized/Black NBR / Black</p> <p>鋁/陽極/黑色 橡膠/黑色</p>

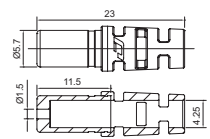
Anti-Kink End Cap 防折端套

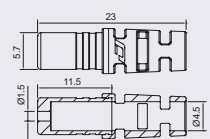

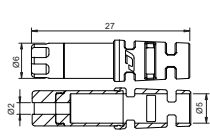



Part No.	Description	Material / Finish
<p>new CC976 Black/黑色</p>  	<p>Anti-kink End Cap Fits 4mm Housing</p> <p>防折端套 適用於4mm外殼</p>	<p>Plastic/Black</p> <p>塑膠/黑色</p>
<p>new CC977 Black/黑色</p>  	<p>Anti-kink End Cap Fits 4.5mm Housing</p> <p>防折端套 適用於4.5mm外殼</p>	<p>Plastic / Black</p> <p>塑膠/黑色</p>
<p>new CC978 Black/黑色</p>  	<p>Anti-kink End Cap Fits 5mm Housing</p> <p>防折端套 適用於5mm外殼</p>	<p>Plastic / Black</p> <p>塑膠/黑色</p>



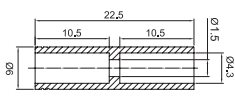

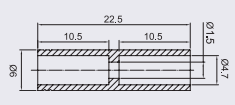

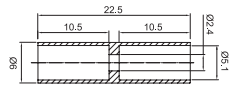



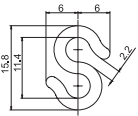

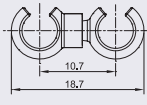
ACCESSORIES

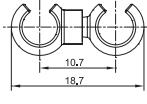
Housing Parts

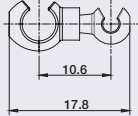
Connect End Cap 連接端套

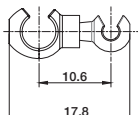
Part No.			Description	Material / Finish
CC729SJ			Double-Ended Housing Connector 4.0 mm Derailer Housing 雙邊外殼導引端套 4.0mm變速外殼	Alloy / Silver 鋁合金/銀色
CC728SJ			Double-Ended Housing Connector 4.5 mm Derailer Housing 雙邊外殼導引端套 4.5mm變速外殼	Alloy / Silver 鋁合金/銀色
CC328AS-J			Double-Ended Housing Connector 5.0mm Brake housing 雙邊外殼導引端套 5.0mm煞車外殼	Alloy / Silver 鋁合金/銀色

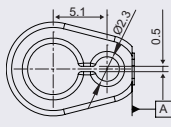
Other 其他零件

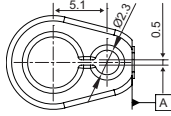
Part No.			Description	Material / Finish
CC115-9			S Housing Holder, Fits 4 & 5mm housings S型導管集線器, 適用於4、5mm外殼	Plastic/Black 塑膠/黑色
CM143			Rotating Hook, Fits 4mm & 5mm housings 導管集線器, 適用於4、5mm外殼	Plastic/Black 塑膠/黑色
CM143W			Rotating Hook, Fits 4mm & 5mm housings 導管集線器, 適用於4、5mm外殼	Plastic/White 塑膠/白色
new CM143-1			Rotating Hook, Fits 2.5mm E-shift & 5mm housing 導管集線器 適用於2.5mm電線及5mm外殼	Plastic/Black 塑膠/黑色
new CM143W-1			Rotating Hook, Fits 2.5mm E-shift & 5mm housing 導管集線器 適用於2.5mm電線及5mm外殼	Plastic/White 塑膠/白色
new CCG060BJ			Wire Hook, Fits 2.5mm E-shift & 5mm housing 雙孔整線器 適用於2.5mm電線及5mm外殼	Silicon Gel /Black 矽膠/黑色
new CCG060WJ			Wire Hook, Fits 2.5mm E-shift & 5mm housing 雙孔整線器 適用於2.5mm電線及5mm外殼	Silicon Gel /White 矽膠/白色

Other 其他零件

Part No.	Description	Material / Finish
<p>CC333-1</p>  	<p>Housing Holder, Fits V-Brake 導管集線器, 適用於V型夾器後剎端</p>	<p>Plastic/Black 塑膠/黑色</p>
<p>CCG004QBG</p>  	<p>Dirt Guard Fits 4 & 4.5mm Nosed End Cap 橡膠防塵套, 適用4、4.5mm鼠尾端套</p>	<p>Silicon Gel/Black 矽膠/黑色</p>
<p>CCG004QGG</p>  	<p>Dirt Guard Fits 4 & 4.5mm Nosed End Cap 橡膠防塵套, 適用4、4.5mm鼠尾端套</p>	<p>Silicon Gel/Silver 矽膠/銀色</p>
<p>CCG014B</p>  	<p>Dirt Guard, Fits 4mm & 4.5mm Nosed End Cap 外殼防水套, 適用於4mm、4.5mm鼠尾端套</p>	<p>Silicon Gel/Black 矽膠/黑色</p>
<p>CCG014R</p>  	<p>Dirt Guard, Fits 4mm & 4.5mm Nosed End Cap 外殼防水套, 適用於4mm、4.5mm鼠尾端套</p>	<p>Silicon Gel/Red 矽膠/紅色</p>
<p>new CCG047B</p>  	<p>Grub Seals, Fits Seal system Brake and Shift liner 迷你密封保護套 適用於全防護系統煞車與變速內管</p>	<p>Silicon Gel /Black 矽膠/黑色</p>











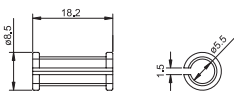

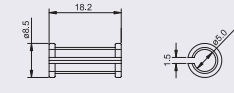

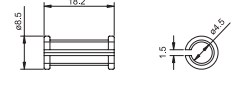

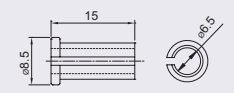

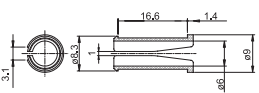
ACCESSORIES

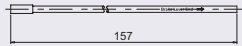
Housing Parts

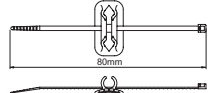
Tube Tops 保護套系列

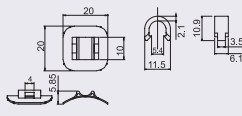
Part No.			Description	Material / Finish
CCG017-BJ			Tube Tops 3G™ Frame Protector, Fits 4, 4.5 & 5mm housing Clamp Type 3G C型扣式車架保護套, 適用於4、4.5、5mm外殼	TPR/Black Black logo TPR橡膠/黑色
CCG017-WJ			Tube Tops 3G™ Frame Protector, Fits 4, 4.5 & 5mm housing Clamp Type 3G C型扣式車架保護套, 適用於4、4.5、5mm外殼	TPR/White White logo TPR橡膠/白色
CCG025-BJ			Tube Tops 3G™ Frame Protector, Fits 5.5mm housing, Clamp Type 3G C型扣式車架保護套, 適用於5.5mm外殼	TPR/Black Black logo TPR橡膠/黑色
CCG025-WJ			Tube Tops 3G™ Frame Protector, Fits 5.5mm housing, Clamp Type 3G C型扣式車架保護套, 適用於5.5mm外殼	TPR/White White logo TPR橡膠/白色
CCG037			Tube Tops 4G, Frame Protector, Fit 4, 4.5 & 5mm housing, Slide type 4G車架保護套, 套入方式組裝, 適用於4、4.5、5mm外殼	Silicon Gel/Black Yellow logo 矽膠/黑色 黃色Logo
CCG043BJY			Tube Tops™ Frame Protector, Fits 4, 4.5 & 5mm Frame, Slide type. 車架保護套,以套入方式組裝, 適用於4、4.5、5mm外殼	Silicon gel/Black Yellow logo 矽膠/黑色 黃色Logo
CCG043TJS			Tube Tops™ Frame Protector, Fits 4, 4.5 & 5mm Frame, Slide type. 車架保護套,以套入方式組裝, 適用於4、4.5、5mm外殼	Silicon gel/ Translucent Silver logo 矽膠/ 透明 灰色Logo
CCG052B			Mini Tube Tops™ Frame Protector, Fits 4, 4.5 & 5mm housings, Slide type, 迷你型車架保護套,以套入方式組裝, 適用於4、4.5、5mm外殼	Silicon Gel Black 矽膠/黑色
CCG052T			Mini Tube Tops™ Frame Protector, Fits 4, 4.5 & 5mm housings, Slide type, 迷你型車架保護套,以套入方式組裝, 適用於4、4.5、5mm外殼	Silicon Gel Translucent 矽膠/半透明
CCG052R			Mini Tube Tops™ Frame Protector, Fits 4, 4.5 & 5mm housings, Slide type, 迷你型車架保護套,以套入方式組裝, 適用於4、4.5、5mm外殼	Silicon Gel Red 矽膠/紅色

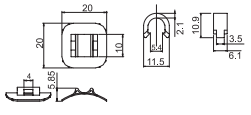

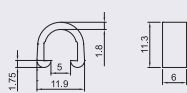







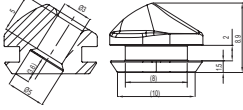

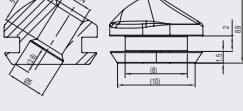
Frame Parts 車架零件

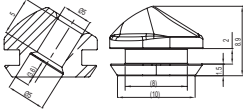
Part No.			Description	Material / Finish
CC359			Housing/Hose Guide Fits Frame Loops 5.5mm 車架止栓導管座, 適用於5.5mm外殼	Plastic / Black 塑膠/黑色
CC359-1			Housing/Hose Guide Fits Frame Loops 5mm 車架止栓導管座, 適用於5mm外殼	Plastic / Black 塑膠/黑色
CC359-2			Housing/Hose Guide Fits Frame Loops 4 & 4.5mm 車架止栓導管座, 適用於4、4.5mm外殼	Plastic / Black 塑膠/黑色
CC359-4			Housing/Hose Guide one side Fits Frame Loops 4 & 4.5mm 車架止栓導管座,單邊 適用於4、4.5mm外殼	Plastic / Black 塑膠/黑色
CC270-1			Housing/Hose guide frame loop Fits 4 & 5mm housings 車架止栓導管座,適用4、5mm外殼	Plastic / Black 塑膠/黑色
CM063			EZ-bend super-flexible housing segment is designed for easy set-up of Kevlar® reinforced compressionless housings on road bike handlebars 公路車手把專用導線連結彎管· 搭配KEB輕量化外殼專用	Steel W/Alloy End Tips 透明外殼/鋁端套
CME011			Stick-on Cable Guide, 3M adhesive attached 塑膠導線座, 3M背膠設計	Plastic / Black 塑膠/黑色
CME013B			Alloy Stick-on Cable Guide, 3M adhesive attached 鋁合金導線座, 3M背膠設計	Alloy / Black 鋁/黑色
CME013S			Alloy Stick-on Cable Guide, 3M adhesive attached 鋁合金導線座, 3M背膠設計	Alloy / Silver 鋁/銀色
CCZ021PB			C Clip Frame Loop Housing Guide C型車架止栓專用外殼扣環	Plastic/Black 尼龍/黑色

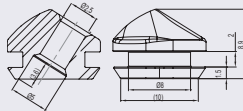
ACCESSORIES

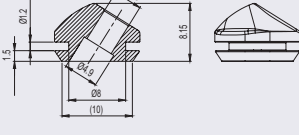

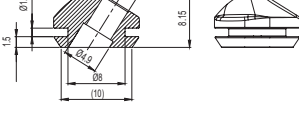
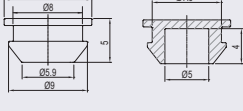

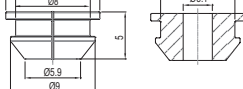





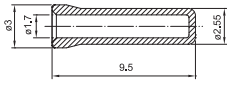

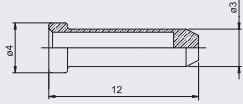

Bicycle Frame Parts

Frame Parts 車架零件

Part No.			Description	Material / Finish
CCN007NB			Plug for Internal Frame Routing SHIMANO Di2 2.0mm Frame 車架止栓/剖溝保護套 適用SHIMANO Di2 車架厚度2.0mm	NBR / Black 橡膠/黑色
CCN007NB-1			Plug for Internal Frame Routing 4mm Derailleur Housing 2.0mm Frame 車架止栓/剖溝保護套 適用4mm變速外殼 車架厚度2.0mm	NBR / Black 橡膠/黑色
CCN007NB-2			Plug for Internal Frame Routing 5mm Brake Housing 2.0mm Frame 車架止栓/剖溝保護套 適用5mm煞車外殼 車架厚度2.0mm	NBR / Black 橡膠/黑色
CCN007NB-3			Plug for Internal Frame Routing SHIMANO Ultegra Di2 2.0mm Frame 車架止栓/剖溝保護套 適用SHIMANO Ultegra Di2 車架厚度2.0mm	NBR / Black 橡膠/黑色
new CCN027-1			Plug for Internal Frame Routing 5mm Brake Housing 1.2mm Frame 車架止栓/剖溝保護套 適用5mm煞車外殼 車架厚度1.2mm	NBR/ Black 橡膠/ 黑色
new CCN027-3			Plug for Internal Frame Routing 4mm Derailleur Housing 1.2mm Frame 車架止栓/剖溝保護套 適用4mm變速外殼 車架厚度1.2mm	NBR/ Black 橡膠/ 黑色
new CCN027-5			Plug for Internal Frame Routing SHIMANO Di2 1.2mm Frame 車架止栓/剖溝保護套 適用SHIMANO Di2 車架厚度1.2mm	NBR/ Black 橡膠/ 黑色
CCN009			Plug for Internal Frame Routing For Close type 車架止栓保護套 適用於無孔徑	EPDM / Black 橡膠/黑色
CCN009-1			Plug for Internal Frame Routing SHIMANO Di2 車架止栓/剖溝保護套 適用SHIMANO Di2	EPDM / Black 橡膠/黑色



Cable Tips 線尾套系列

Part No.	Description	Material / Finish				
 <p>CC117-A Silver/銀色</p>	 <p>Cable Crimps, Fits 1.0 - 1.2mm cables, Open type</p> <p>內線尾套, 適用1.0 - 1.2mm線徑 (變速內線適用)</p>	<p>Alloy / Anodized</p> <p>鋁/陽極</p>				
 <p>CC117-AO Gold/金色</p>	 <p>CC117-AB Black/黑色</p>	 <p>CC117-A06 Red/紅色</p>				
 <p>CC117-C Silver/銀色</p>	 <p>CC117-CO Gold/金色</p>  <p>Cable Crimps, Fit 1.0 - 1.8mm cables, Open type For Brake and shifting system</p> <p>內線尾套,適用1.0 - 1.8mm線徑 (剎車、變速內線適用)</p>	<p>Alloy / Anodized</p> <p>鋁/陽極</p>				
 <p>CC117-C06 Red/紅色</p>	 <p>CC117-C07 Black/黑色</p>	 <p>CC117-C08 Blue/藍色</p>	 <p>CC117-C24 Pink/粉紅色</p>	 <p>CC117-C61 Cash Green/綠色</p>	 <p>CC117-C68 Purple/紫色</p>	 <p>CC117-CJ6 Tango/橘色</p>

ACCESSORIES

Cable Parts









Non-Crimp 小天使系列



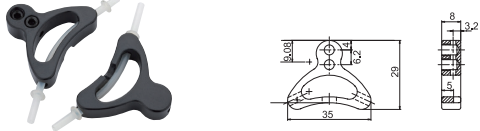

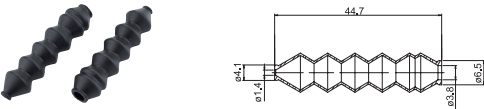





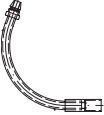

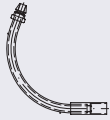
Part No.	Description	Material / Finish
 CM743OJ Gold/金色	 Re-useable For Brake and Shifting system • 可重複使用 • 適用於煞車及變速內線	NBR / Alloy / Anodized 橡膠/鋁/陽極
 CM743SJ Silver/銀色		
 CM743BJ Black/黑色		
 CM743RJ Red/紅色		

Cable Dounts 防刮墊圈系列

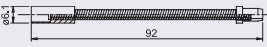
Part No.	Description	Material / Finish
<p>CC170-B</p>  	<p>Cable Donuts, Fit 1.1 - 1.2mm cables, Octagonal Shape</p> <p>O型環-八角形狀(內線防刮墊圈), 適用1.1 - 1.2mm線徑(變速內線)</p>	<p>Polymer / Black</p> <p>橡膠/黑色</p>
<p>CC170-C</p>  	<p>Cable Donuts, Fit 1.1 - 1.2mm cables, Octagonal Shape</p> <p>O型環-八角形狀(內線防刮墊圈), 適用1.1 - 1.2mm線徑(變速內線)</p>	<p>Polymer / Translucent</p> <p>橡膠/透明</p>
<p>CC170-BO</p>  	<p>Cable Donuts, Fit 1.1 - 1.2mm cables, Round shape</p> <p>O型環-圓形形狀(內線防刮墊圈), 適用1.1 - 1.2mm線徑(變速內線)</p>	<p>Polymer / Black</p> <p>橡膠/黑色</p>
<p>CC170-CO</p>  	<p>Cable Donuts, Fit 1.1 - 1.2mm cables, Round shape</p> <p>O型環-圓形形狀(內線防刮墊圈), 適用1.1 - 1.2mm線徑(變速內線)</p>	<p>Polymer / Translucent</p> <p>橡膠/透明</p>
<p>CC171-B</p>  	<p>Cable Donuts, Fit 1.1 - 1.8mm cables, Octagonal Shape</p> <p>O型環-八角形狀(內線防刮墊圈), 適用1.1 - 1.8mm線徑(剎車內線)</p>	<p>Polymer / Black</p> <p>橡膠/黑色</p>
<p>CC171-C</p>  	<p>Cable Donuts, Fit 1.1 - 1.8mm cables, Octagonal Shape</p> <p>O型環-八角形狀(內線防刮墊圈), 適用1.1 - 1.8mm線徑(剎車內線)</p>	<p>Polymer / Translucent</p> <p>橡膠/透明</p>
<p>CC171-BO</p>  	<p>Cable Donuts, Fit 1.1 - 1.8mm cables, Round Shape</p> <p>O型環-圓形(內線防刮墊圈), 適用1.1 - 1.8mm線徑(剎車內線)</p>	<p>Polymer / Black</p> <p>橡膠/黑色</p>
<p>CC171-CO</p>  	<p>Cable Donuts, Fit 1.1 - 1.8mm cables, Round Shape</p> <p>O型環-圓形(內線防刮墊圈), 適用1.1 - 1.8mm線徑(剎車內線)</p>	<p>Polymer / Translucent</p> <p>橡膠/透明</p>

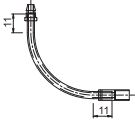

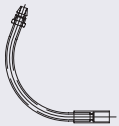



ACCESSORIES

Part No.	Description	Material / Finish
<p data-bbox="99 500 240 530">CC128-07</p> 	<p data-bbox="987 470 1117 523">Cable Hanger Fits Canti Brakes</p> <p data-bbox="987 539 1214 562">吊線座含內管·煞車夾器用</p>	<p data-bbox="1377 482 1539 505">Aluminum / Black</p> <p data-bbox="1421 523 1485 546">鋁/黑色</p>
<p data-bbox="99 805 240 835">CCG044B</p> 	<p data-bbox="987 787 1149 810">V-Brake Pipe Boot</p> <p data-bbox="987 821 1149 844">V刹導管專用保護套</p>	<p data-bbox="1385 787 1523 810">Rubber / Black</p> <p data-bbox="1412 828 1495 851">橡膠/黑色</p>
<p data-bbox="99 1104 196 1134">CC198</p> 	<p data-bbox="987 1086 1157 1108">V-brake pipe boot</p> <p data-bbox="987 1120 1149 1143">V刹導管專用保護套</p>	<p data-bbox="1385 1086 1523 1108">Rubber / Black</p> <p data-bbox="1412 1127 1495 1150">橡膠/黑色</p>
<p data-bbox="99 1409 217 1439">CC220A</p> 	<p data-bbox="987 1386 1133 1409">Guide Pipe 82.5°</p> <p data-bbox="987 1430 1125 1453">煞車器彎管82.5°</p>	<p data-bbox="1369 1375 1539 1428">Stainless steel tube w/ alloy end cap</p> <p data-bbox="1377 1444 1531 1467">不鏽鋼導管/鋁端套</p>
<p data-bbox="99 1715 217 1744">CC221A</p> 	<p data-bbox="987 1692 1125 1715">Guide Pipe 90°</p> <p data-bbox="987 1735 1117 1758">煞車器彎管90°</p>	<p data-bbox="1369 1678 1539 1731">Stainless steel tube w/ alloy end cap</p> <p data-bbox="1377 1747 1531 1770">不鏽鋼導管/鋁端套</p>
<p data-bbox="99 2013 212 2043">CC221T</p> 	<p data-bbox="987 1990 1125 2013">Guide Pipe 90°</p> <p data-bbox="987 2034 1117 2057">煞車器彎管90°</p>	<p data-bbox="1360 1976 1547 2029">Stainless steel tube w/ stainless end cap</p> <p data-bbox="1360 2045 1547 2068">不鏽鋼導管/不鏽鋼端套</p>

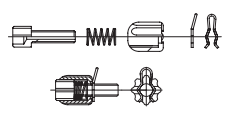
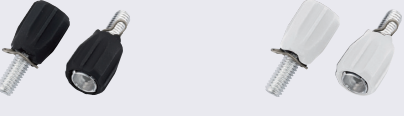
Part No.	Image		Description	Material / Finish
CC222A			Guide pipe 110° 煞車器彎管110°	Stainless steel tube w/ alloy end cap 不鏽鋼導管/鋁端套
CC222T			Guide pipe 110° 煞車器彎管110°	Stainless steel tube w/ stainless end cap 不鏽鋼導管/不鏽鋼端套
CC223A			Guide pipe 135° 煞車器彎管135°	Stainless steel tube w/ alloy end cap 不鏽鋼導管/鋁端套
CC401-2			Guide pipe, 0~180° flexible 自由式煞車器彎管0°~180°	Stainless steel tube w/ alloy end cap 不鏽鋼導管/鋁端套
CMD021B3			POP guide pipe 90°, alloy end tips (designed specially for Kevlar® reinforced cable housing) POP煞車器彎管90°鋁端套,克維拉 (Kevlar)外殼專用	Stainless steel tube w/ brass end cap 不鏽鋼管/不鏽鋼端套
CMD022B3			POP guide pipe 110°, alloy end tips (designed specially for Kevlar® reinforced cable housing) POP煞車器彎管110°鋁端套,KEB輕量化 外殼專用	Stainless steel tube w/ brass end cap 不鏽鋼管/不鏽鋼端套
CMD221SO			Adjuster guide pipe 90° alloy end tips 90°鋁端頭轉接彎管 (內含彈簧緩衝結構)	Stainless steel tube w/ alloy end cap 不鏽鋼管/鋁端套

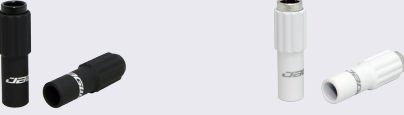
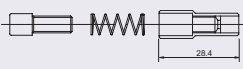

Adjuster 調整螺絲

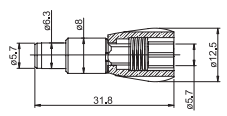
Part No.		Description	Material / Finish
<p>Rubberized coating</p>  <p>CM019B-1 Black/黑色</p> <p>CM019W White/白色</p> 		<p>M5 index adjuster, Shimano® STI shifting cable boss compatible Taiwan Patent: 168957</p> <p>M5定格調整螺絲· 公路車下管止栓用· 適用於Shimano® STI系統 台灣專利:168957</p>	<p>Rubberized Cap/ Steel Bolt/Silver</p> <p>皮革漆/ 鐵螺絲/銀色</p>
<p>Rubberized coating</p>  <p>CM136B Black/黑色</p> <p>CM136W White/白色</p> 		<p>M5 index adjuster, Shimano® STI shifting cable boss compatible Taiwan Patent: 168957</p> <p>M5定格調整螺絲· 公路車下管止栓用· 適用於Shimano® STI系統 台灣專利:168957</p>	<p>Rubberized Cap/ Alloy Bolt/Silver</p> <p>皮革漆/ 鋁螺絲/銀色</p>
 <p>CM093J</p> 		<p>Mini in-line adjuster Fits 4mm shift housing</p> <p>迷你同軸式調整螺絲 適用於4mm變速外殼</p>	<p>Alloy / Anodized / Titanium finish</p> <p>鋁/陽極/鈦色</p>
<p>Rubberized coating</p>  <p>CM160BJ Black/黑色</p> <p>CM160WJ White/白色</p> 		<p>Mini in-line adjuster Fits 4mm shift housing</p> <p>迷你同軸式調整螺絲 適用於4mm變速外殼</p>	<p>Alloy / Rubberized coating</p> <p>鋁/皮革漆</p>
<p>Rubberized coating</p>  <p>CM157BJ</p> 		<p>Rocket adjuster, For Shimano® STI Shift Levers. Adds index adjustments at the lever.</p> <p>“火箭”調整螺絲· 適用於Shimano STI公路車手把</p>	<p>Alloy bolt / Argon plated / Black</p> <p>Rubberized cap / Black</p> <p>鋁螺絲/鍍氬/黑 皮革漆/黑</p>



Part No.	Description	Material / Finish
----------	-------------	-------------------



CM233-1DJ
Titanium/鈦色



CM233-1BJ
Black/黑色



CM233-1SJ
Silver/銀色

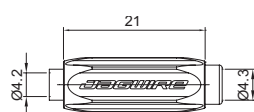

New- Inline Index/ Detent Adjusters
Fits 4mm shift housing

定格式調整螺絲
適用於4mm變速外殼

Alloy/Anodized
鋁/陽極

Rubberized coating



CM233-1WJ

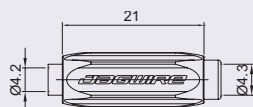

New- Inline Index/ Detent Adjusters
Fits 4mm shift housing

定格式調整螺絲
適用於4mm變速外殼

Alloy/Rubberized/White
鋁/皮革漆/白色



CM272BJ

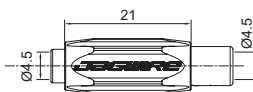

New- Inline Index/ Detent Adjusters
Fits 4.5mm shift housing

定格式調整螺絲
適用於4.5mm變速外殼

Alloy/Anodized/Black
鋁/陽極/黑色



CM265BJ

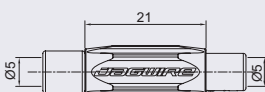

New-Inline index Adjusters
Fits 5mm Brake housing

定格式調整螺絲
適用於5mm煞車外殼

Alloy/Anodized/Black
鋁/陽極/黑色

Exploring New Horizons for Control Systems

For more than 20 years, Jagwire has pioneered new territory in the manufacture of high performance control systems. As an ISO 9001/TS-16949 company we have an unyielding commitment to quality.

Faster, Leaner, Better

Fully committed to process improvement, our experienced engineering staff is always looking for ways to enhance quality, reduce errors and increase customer satisfaction. Partnering with Toyota, we integrated the highly efficient Toyota Production System (TPS). Our balanced blend of automation and manual processes helps us manage flow and volume, resulting in unsurpassed quality and efficiency. And as a member of the Taiwan A-Team manufacturing group, we develop improved business strategies and tactics to reduce lead times, improve quality and cut defects and waste.

Environment & Community

Recognizing our vital role as responsible global citizens, we strive to produce products that meet the exacting requirements of government agencies for performance, safety and environmental impact. Our primary control system products are CPSIA, Proposition 65 and CEN certified.

Chia Cherne Industry Company, Ltd Warranty Policy

EXTENT OF LIMITED WARRANTY

Chia Cherne/Jagwire warrants its products to be free from defects in materials or workmanship for a period of two years after original purchase. This warranty only applies to the original owner and is not transferable. Claims under this warranty must be made through the retailer where the bicycle or the Jagwire product was purchased. Original proof of purchase is required. Complete product warranty information is available by visiting jagwire.com. Or a copy may be requested via email.

Email: info@jagwire.com

Product Safety & Installation

WARNING: Many bicycle service and repair tasks require special knowledge and tools. In order to help minimize the chances of an accident and possible injury, it is critical that you have any installation, repair or maintenance performed by a professional bicycle mechanic or dealer. Do not begin any adjustments or service on your bicycle yourself until you have learned from your mechanic or dealer how to properly complete them. Improper adjustment or service may result in damage to the bicycle or an accident, which can cause serious injury or death.

Consult your dealer or mechanic for help in determining your maintenance requirements. Like any mechanical device, a bicycle and its components are subject to wear and stress. Different materials and mechanisms wear or fatigue from stress at different rates and have different life cycles. If a component's life cycle is exceeded, the component can fail, causing serious injury or death to the rider. Scratches, cracks, fraying of wires and discoloration are signs of stress-caused fatigue and indicate that a part is at the end of its useful life and needs to be replaced. While the materials and workmanship of bicycle components may be covered by a warranty for a specified period of time by the manufacturer, this is no guarantee that the product will last the term of the warranty. Product life is often related to riding style and product care. A component warranty is not meant to suggest that the component cannot be broken or will last forever.

Before installing any component or accessory make sure that it is compatible with your bicycle by checking with your dealer.

WARNING:

1. Riding with improperly adjusted brakes, worn brake pads, worn control cables or housings is dangerous and can result in serious injury or death.
2. Applying brakes too hard or too suddenly can lock up a wheel, which could cause you to lose control and fall. Sudden or excessive application of the front brake may pitch the rider over the handlebars, which may result in serious injury or death.
3. Some bicycle brakes, such as disc brakes and linear-pull brakes are extremely powerful. Take extra care in becoming familiar with these brakes and exercise particular care when using them.
4. Disc brakes can get extremely hot with extended use. Be careful not to touch a disc brake until it has had plenty of time to cool.
5. See the brake manufacturer's instructions for operation and care of your brakes. If you do not have the manufacturer's instructions, see your dealer or contact the brake manufacturer.

WARNING: Jagwire cables, housings and brake pads are not intended for use on any motorized bicycle or vehicle. Any such use could result in a serious personal injury.

Brake Inspection

Inspecting your bicycle's braking systems before each ride is critical to your safety. Check the brakes for proper operation.

- Squeeze the brake levers
- Are the brake quick-releases closed?
- All control cables seated and securely engaged?
- Do the brake pads contact the wheel rim squarely and make full contact with the rim?
- Are the bolts that attach your brake pads to the brake caliper tight?
- Do the brake pads touch the wheel rim within an inch of brake lever movement?
- Can you apply full braking force at the levers without having them touch the handlebar?

If not, your brakes need adjustment. Do not ride the bike until the brakes are properly adjusted by a professional bicycle mechanic.

The effectiveness of braking is dependent on environmental factors and equipment condition over which Jagwire has no control. Consult the owner's manual for your bicycle and a professional bike mechanic or dealer to learn more about proper braking techniques and always practice riding and braking techniques on a flat and level surface prior to riding.

Under wet conditions, the stopping power of your brakes is dramatically reduced. In wet conditions, ride slowly and apply your brakes earlier than you would under normal, dry conditions.

Inspect your brakes, cables and brake pads regularly for damage, and always inspect them thoroughly after any crash or severe impact. If you detect damage, please have your bicycle inspected by a professional bike mechanic or dealer.

Important: If the brake pads are worn until the grooves disappear, replace them with new pads. If wheel rims are excessively worn from braking, replace them with new rims.

Cables

Improper set-up or use of brake control cables can result in loss of control or lead to a serious accident, which could lead to a severe injury.

It is your responsibility to ensure that your brake control system cables are functioning properly before each ride. Consult the owner's manual for your bicycle and a professional bike mechanic or dealer to learn more about proper cable installation and maintenance techniques.

Inspect your cables & housings regularly for damage or wire fraying, and always inspect them thoroughly after any crash or severe impact. If you detect damage, please have your bicycle inspected by a professional bike mechanic or dealer.

Important: If your control system wires begin to fray, your housing end caps show any signs of damage or your housing is kinked, replace them with new products.

Installation Assistance

Downloadable instructions are available on www.jagwire.com, or by contacting Jagwire directly.

Europe - jageurope@nowcompany.com

Asia - service@jagwire.com tw

North & South America - tech@jagwire.com

Trademarks

All trademarks, service marks and trade names of Jagwire and Chia Cherne used herein are trademarks or registered trademarks of the Chia Cherne Industry Company, Ltd. Use of any trademarks or other intellectual property of Chia Cherne, without the express written consent of Chia Cherne, is prohibited.

Copyright (c) 2014—Chia Cherne Industry Company, Ltd.

We Support:

